



aerospace
climate control
electromechanical
filtration
fluid & gas handling
hydraulics
pneumatics
process control
sealing & shielding



Heavy Duty Pneumatic Cylinders

Series 2A / 2AN



ENGINEERING YOUR SUCCESS.

Table of Contents

Specifications and Mountings	1	Ports	46
Design Features	2	Stroke Data / Tie Rod Supports	48
Dimensions 1" - 6" Bore	4	Stop Tubing / Classes	49
Dimensions 7" Bore	14	Cylinder Stroke Chart	50
Dimensions 8" - 14" Bore	16	Acceleration and Deceleration Data	51
Spherical Bearing Mount	26	Deceleration Force / Air Requirements	52
Double Rod Models	28	Cushing Ratings / Air Requirements	53
Cylinder Accessories	29	Rod Wiper / Rod End Boots	56
Linear Alignment Couplers	35	Cylinder Weights	57
Style 55 Rod End	37	Parts Identification / Torque Values	58
How to Order	38	Parts Identification / Seal Kits	59
Model Numbers	39	Gland Cartridges / Rod Seals	60
Series 2AN Non-Lube	40	Gland Cartridge Wrenches	61
Push and Pull Forces	44	Cylinder Safety Guide	62
Operating Fluids	45	Offer of Sale	66

**Parker Series 2A
Air Cylinder**

When the job calls for reliable, heavy-duty performance, specify Series 2A. A 100,000 psi yield strength chrome-plated, case-hardened piston rod. A 125,000 psi yield strength rod-end stud with rolled threads. 100,000 psi yield strength tie rods. With construction like this, the Parker Series 2A is rated for air service to 250 psi. This is one heavy-duty air cylinder that's really heavy duty.

They're truly premium quality cylinders, factory prelubricated for millions of maintenance-free cycles. And to make sure every cylinder is premium quality, we subject each and every one – not just batch samples – to tough inspection and performance tests. See pages 2 and 3 for the inside story on all the features that make Series 2A the high performance, long lasting choice for all your heavy-duty air applications.



In line with our policy of continuing product improvement, specifications and information contained in this catalog are subject to change.

Copyright ©2017 by Parker Hannifin Corporation.
All rights reserved.

PRINTED IN THE U.S.A.

⚠ WARNING

FAILURE OR IMPROPER SELECTION OR IMPROPER USE OF THE PRODUCTS AND/OR SYSTEMS DESCRIBED HEREIN OR RELATED ITEMS CAN CAUSE DEATH, PERSONAL INJURY AND PROPERTY DAMAGE.

This document and other information from the Parker Hannifin Corporation, its subsidiaries and authorized distributors provide product and/or system options for further investigation by users having expertise. It is important that you analyze all aspects of your application, including consequences of any failure and review the information concerning the product or system in the current product catalog. Due to the variety of operating conditions and applications for these products or systems, the user, through its own analysis and testing, is solely responsible for making the final selection of the products and systems and assuring that all performance, safety and warning requirements of the application are met.

The products described herein, including without limitation, product features, specifications, designs, availability and pricing, are subject to change by Parker Hannifin Corporation and its subsidiaries at any time without notice.

Offer of Sale

The items described in this document are hereby offered for sale by Parker Hannifin Corporation, its subsidiaries or its authorized distributors. This offer and its acceptance are governed by provisions stated on a separate page of the document entitled 'Offer of Sale'.

Standard Specifications

- Heavy Duty Service – ANSI/(NFPA) T3.6.7R3-2009 Specifications and Mounting Dimension Standards
- Standard Construction – Square Head – Tie Rod Design
- Nominal Pressure – Up to 250 PSI Air Service
- Standard Fluid – Filtered Air
- Standard Temperature – -10°F to +165°F with standard seals; -10°F to +250°F with fluorocarbon seals.

In line with our policy of continuing product improvement, specifications in this catalog are subject to change.

- Bore Sizes – 1" through 14" (Larger sizes available)
- Piston Rod Diameter – 1/2" through 5 1/2"
- Mounting Styles – 14 standard styles at various application ratings
- Strokes – Available in any practical stroke length
- Cushions – Optional at either end or both ends of stroke. "Float Check" at cap end.
- Rod Ends – Three Standard Choices – Specials to Order
 *See page 41, "Operating Fluids and Temperature Range" for higher temperature service.

Note: Series 2A Air Cylinders fully meet ANSI/(NFPA) T3.6.7R3-2009 Specifications and Mounting Dimension Standards for Square Head Industrial Fluid Power Cylinders. Parker Style TB, JB, HB, C, DB, and BB are available in 7" bore size, see pages 14-15.

Available Mounting Styles

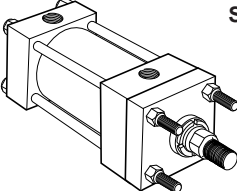
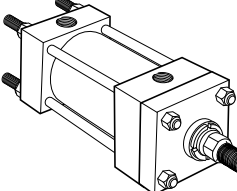
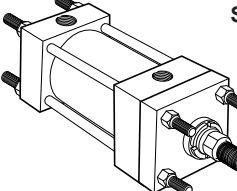
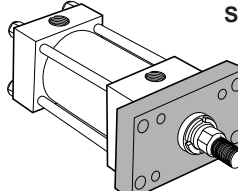
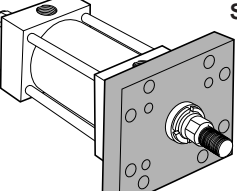
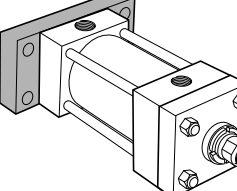
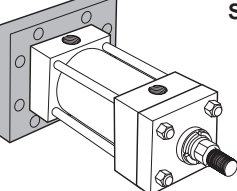
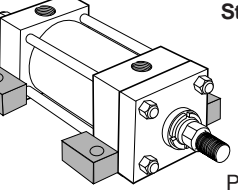
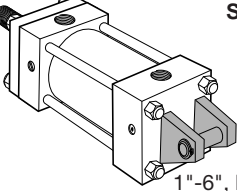
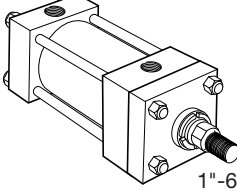
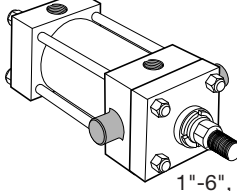
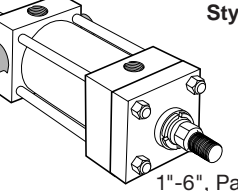
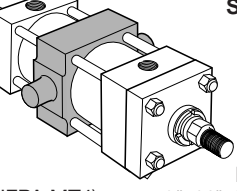
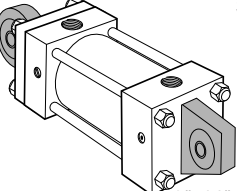
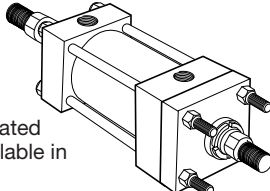
<p>Tie Rods Extended Head End Style TB</p>  <p>1"-6", Page 4 8"-14", Page 16 (NFPA MX3)</p>	<p>Tie Rods Extended Cap End Style TC</p>  <p>1"-6", Page 4 8"-14", Page 16 (NFPA MX2)</p>	<p>Tie Rods Extended Both Ends Style TD</p>  <p>1"-6", Page 4 8"-14", Page 16 (NFPA MX1)</p>	<p>Head Rectangular Flange Style J</p>  <p>(NFPA MF1) 1"-6", Page 4</p>
<p>Head Square Flange Style JB</p>  <p>1"-6", Page 6 8"-14", Page 16 (NFPA MF5)</p>	<p>Cap Rectangular Flange Style H</p>  <p>(NFPA MF2) 1"-6", Page 4</p>	<p>Cap Square Flange Style HB</p>  <p>1"-6", Page 6 8"-14", Page 16 (NFPA MF6)</p>	<p>Side Lug Style C</p>  <p>1"-6", Page 8 8"-14", Page 18 (NFPA MS2)</p>
<p>Cap Fixed Clevis Style BB</p>  <p>1"-6", Page 12 8"-14", Page 22 (NFPA MP1)</p>	<p>Side Tapped Style F</p>  <p>1"-6", Page 8 8"-14", Page 20 (NFPA MS4)</p>	<p>Head Trunnion Style D</p>  <p>1"-6", Page 10 8"-14", Page 24 (NFPA MT1)</p>	<p>Cap Trunnion Style DB</p>  <p>1"-6", Page 10 8"-14", Page 24 (NFPA MT2)</p>
<p>Intermediate Fixed Trunnion Style DD</p>  <p>1 1/2"-6", Page 10 8"-14", Page 24 (NFPA MT4)</p>	<p>Spherical Bearing Style SB</p>  <p>1 1/2"-6", Page 26 8"-14", Page 27</p>	<p>Double Rod Cylinders Style KTB Shown</p>  <p>Most of the above illustrated mounting styles are available in double rod cylinders. See page 28.</p>	

The inside story on why Series 2A is your best choice in heavy duty pneumatic cylinders

Primary Seal – Unique Serrated Lipseal™ is a proven leakproof design, completely self-compensating and self-relieving to withstand variations and conform to mechanical deflection that may occur.

Piston Rod Stud – Furnished on 2" diameter rods and smaller when standard style #4 rod end threads are required. Also available in 2 times the catalog "A" dimension length. Studs have rolled threads and are made from high strength steel. Anaerobic adhesive is used to permanently lock the stud to the piston rod.

"Jewel" Rod Gland Assembly – Externally removable without cylinder disassembly. Long bearing surface is inboard of the seals, assuring positive lubrication from within the cylinder. An "O" ring is used as a seal between gland and head, and also serves as a prevailing torque-type lock.

Secondary Seal – Double-Service Wiperseal™ – acts as a secondary pressure seal on the extend stroke and cleans the rod on the return stroke.

High Strength Tie Rods – Made from 100,000 psi minimum yield steel with rolled threads for added strength.

Adjustable Floating Cushions – Cushions are optional and can be supplied at head end, cap end, or both ends without change in envelope or mounting dimensions.

Steel Head – Bored and grooved to provide concentricity for mating parts.

Ports – NPTF ports are standard.

End Seals – Pressure-actuated cylinder body-to-head and cap "O" rings.

The Cylinder Body – Hard chrome-plated bore, steel tubing honed to a micro inch finish on 1 1/2" through 14" bore sizes. 1" bore size is aluminum with hard-coated bore.

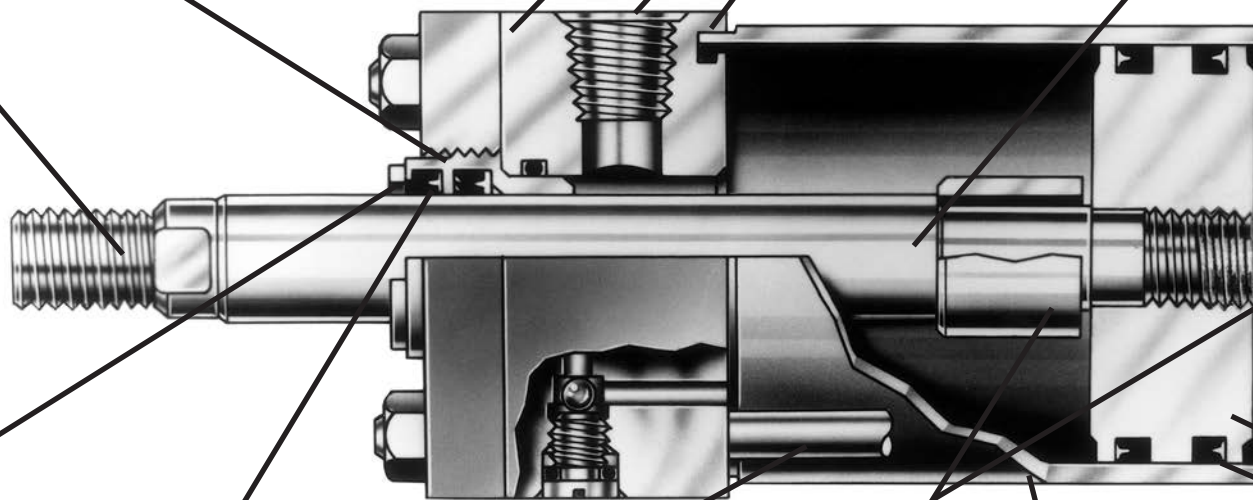

Adjustable floating cushions

Cushions are optional, and can be supplied at head end, cap end, or both ends without change in envelope or mounting dimensions. All Parker cushions are adjustable. The Series 2A cylinder design incorporates the longest cushion sleeve and cushion spear that can be provided in the standard envelope without decreasing the rod bearing and piston bearing lengths.

(1) When a cushion is specified at the head end:

- a. A self-centering sleeve is furnished on the piston rod assembly.
- b. A needle valve is provided that is flush with the side of the head when wide open. It may be identified by the fact that it is socket-keyed. It is located on side number 2, in all mounting styles except D, DB and DD. In these styles it is located on side number 3.
- c. A springless check valve is provided that is also flush with the side of the head and is mounted

adjacent to the needle valve except on certain bores of mounting style C where it is mounted opposite the needle valve. It may be identified by the fact that it is slotted.

- d. The check and needle valves are interchangeable in the head.
- (2) When a cushion is specified at the cap end:
- a. A cushion spear is provided on the piston rod assembly.
 - b. A "float check" self-centering bushing is provided which incorporates a large flow check valve for fast "out-stroke" action.
 - c. A socket-keyed needle valve is provided that is flush with the side of the cap when wide open. It is located on side number 2 in all mounting styles except D, DB, and DD. In these styles it is located on side number 3.

Piston Rod – Medium carbon steel, induction case-hardened, hard chrome-plated and polished to 10 RMS finish. Piston rods are made from 85,000 to 100,000 psi minimum yield material in 1/2" through 4" diameters. Larger diameters vary between 57,000 and 90,000 psi minimum material, depending on rod diameter. The piston thread equals the catalog style #4 rod end thread for each rod diameter to assure proper piston-to-rod thread strength. Two wrench flats are provided for rod end attachment.

Ports – NPTF ports are standard.

Steel Cap – Bored and grooved to provide concentricity for mating parts.

Alloy Steel Tie Rod Nuts

Align-A-Groove – A 3/16" wide surface machined at each end of the cylinder body. Makes precise mounting quick and easy.

One-Piece Nodular Iron Piston – The wide piston surface contacting cylinder bore reduces bearing loads. Anaerobic adhesive is used to permanently lock and seal the piston to the rod.

Piston Lipseal – Fully dynamic and self-compensating for variations in pressure, mechanical deflections and wear.

The exclusive "Jewel" gland gives you longer cylinder life, better performance and lower costs.



An extra-long inboard bearing surface insures lubrication from within the cylinder. Outboard of the bearing surface are two leakproof seals – The Lipseal and Wiperseal. The serrated Lipseal (primary seal) is completely self-compensating and self-relieving. It adjusts to mechanical deflections or any pressure variation from near-zero to rated operating pressure. The result is positive, no-leak sealing – regardless of conditions.

The Wiperseal does double duty. On the advance stroke, it acts as a secondary pressure seal. On the return, it wipes away any dirt on the rod. This means less wear on bearing surfaces and internal parts. Longer life for working parts. And, less loss of fluid. Plus, you can replace a "Jewel" gland without removing the tie rods or the retainer. Just a few twists with a spanner wrench does the job.

Prelubricated Wearing Surfaces

Parker Series 2A Air Cylinders are factory prelubricated. Lube-A-Cyl applied to seals, piston, cylinder bore, piston rod and gland surfaces provides lubrication for normal operation. Lube-A-Cyl has been field and laboratory tested, and is recommended by Parker for air cylinders where lubricant should remain in the cylinder and not be expelled into the atmosphere.

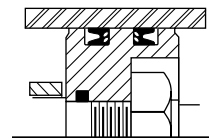

Piston with Retainer Nut – Optional at extra charge.

Cushion Length

Cylinder Bore (Inches)	Rod Diameter* (Inches)	Rod Number	Cushion Length (Inches)	
			Head*	Cap
1 1/2	5/8	1	7/8	13/16
	1	2	7/8	13/16
2	5/8	1	7/8	13/16
	1 3/8	2	7/8	13/16
2 1/2	5/8	1	7/8	13/16
	1 3/4	2	7/8	13/16
3 1/4	1	1	1 1/8	1
	2	2	13/16	1
4	1	1	1 1/8	1
	2 1/2	2	13/16	1
5	1	1	1 1/8	1
	3 1/2	2	13/16	1

Cylinder Bore (Inches)	Rod Diameter* (Inches)	Rod Number	Cushion Length (Inches)	
			Head*	Cap
6	1 3/8	1	1 3/8	1 1/4
	4	2	1 1/16	1 1/4
7	1 3/8	1	1 1/16	1 1/4
	2	4	1 1/16	1 1/4
8	1 3/8	1	1 1/16	1 1/4
	5 1/2	2	15/16	1 1/4
10	1 3/4	1	1 5/16	1 3/4
	5 1/2	0	1 3/16	1 3/4
12	2	1	1 5/16	1 3/4
	5 1/2	9	1 3/16	1 3/4
14	2 1/2	1	1 3/4	2
	5 1/2	8	1 11/16	2

*Head end cushions for rod diameters not listed have cushion lengths with the limits shown. For cushion selection and sizing see pages 52-53.

Tie Rods Extended
Style TB
(NFFPA Style MX3)

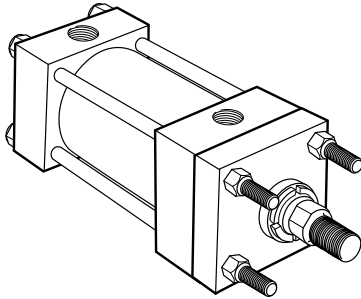

Basic Mounting (T) —
NFFPA MX0 — no tie rods extended can be supplied upon request.

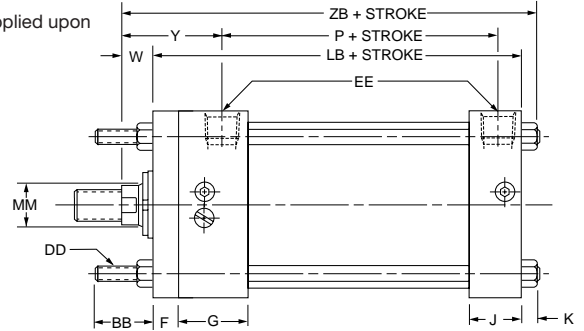
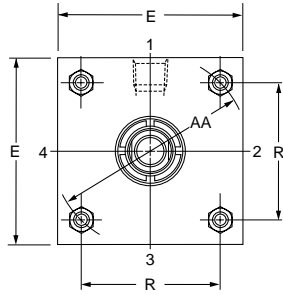

Style TB (NFFPA MX3), Head Tie Rods Extended, illustrated: Style TC (NFFPA MX2), Cap Tie Rods Extended; and Style TD (NFFPA MX1), Both Ends Tie Rods Extended are also available. All "T" styles can be dimensioned from Style TB drawing at right.

Head Rectangular Flange
Style J
(NFFPA Style MF1)

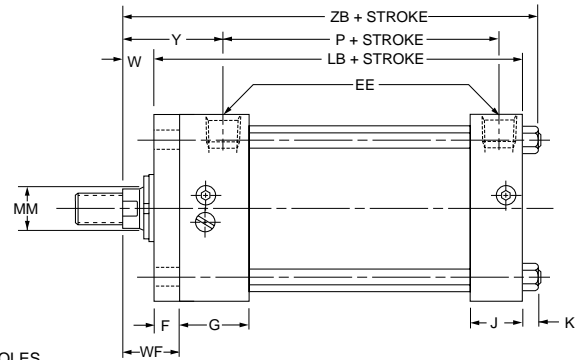
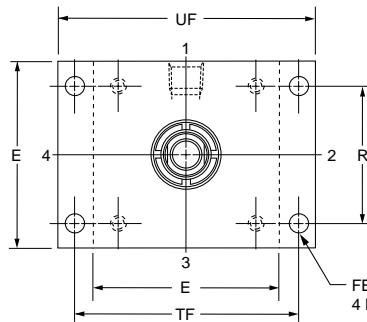
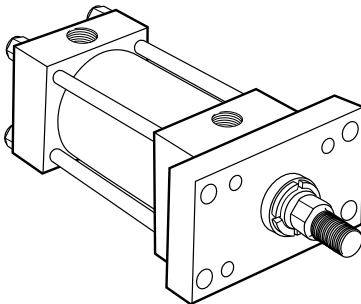

Cap Rectangular Flange
Style H
(NFFPA Style MF2)

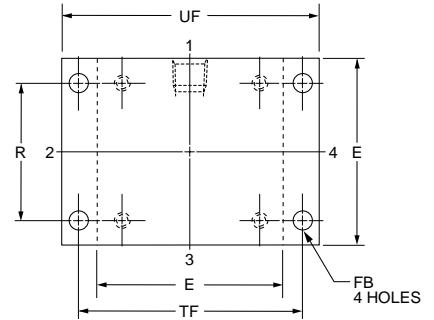
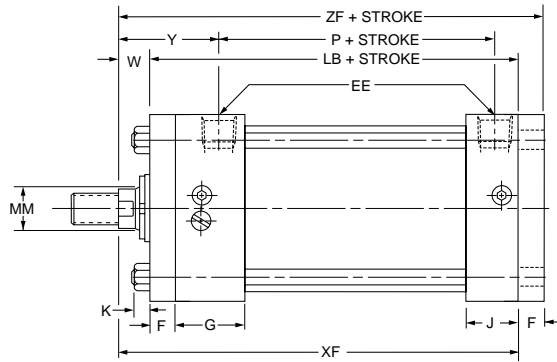
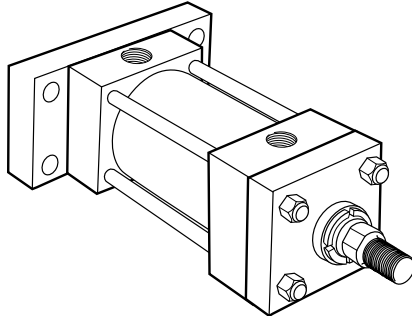

Rod End Dimensions — see table 2

Thread Style 4
(NFFPA Style SM)
Small Male

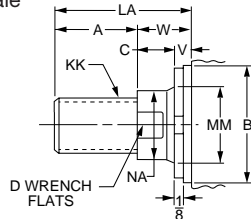

A high strength rod end stud is supplied on thread style 4 through 2" diameter rods. Larger sizes or special rod ends are cut threads. Style 4 rod ends are recommended where the workpiece is secured against the rod shoulder. When the workpiece is not shouldered, style 4 rod

Thread Style 8
(NFFPA Style IM)
Intermediate Male

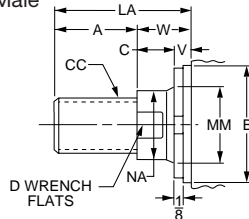

ends are recommended through 2" piston rod diameters and style 8 rod ends are recommended on larger diameters. Use style 9 for applications where female rod end threads are required. If rod end is not specified, style 4 will be supplied.

Thread Style 9
(NFFPA Style SF)
Small Female

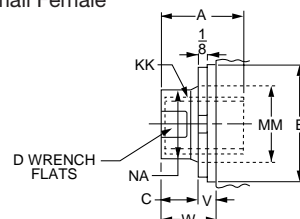

"Special" Thread Style 3

Special thread, extension, rod eye, blank, etc., are also available.

To order, specify "Style 3" and give desired dimensions for KK, A and W or WF. If otherwise special, furnish dimensioned sketch.

Table 1—Envelope and Mounting Dimensions

Bore	AA	BB	DD	E	EE NPTF	F	FB	G	J	K	R	TF	UF	Add Stroke	
														LB	P
1*	1.53	3/4	10-24	■	1/4	3/8	1/4	1 1/2	1	3/16	1.08	2	2 1/2	3 7/8	2 1/8
1 1/2	2.02	1	1/4-28	2	3/8**	3/8	5/16	1 1/2	1	1/4	1.43	2 3/4	3 3/8	4	2 1/4
2	2.6	1 1/8	5/16-24	2 1/2	3/8**	3/8	3/8	1 1/2	1	5/16	1.84	3 3/8	4 1/8	4	2 1/4
2 1/2	3.1	1 1/8	5/16-24	3	3/8**	3/8	3/8	1 1/2	1	5/16	2.19	3 7/8	4 5/8	4 1/8	2 3/8
3 1/4	3.9	1 3/8	3/8-24	3 3/4	1/2	5/8	7/16	1 3/4	1 1/4	3/8	2.76	4 11/16	5 1/2	4 7/8	2 5/8
4	4.7	1 3/8	3/8-24	4 1/2	1/2	5/8	7/16	1 3/4	1 1/4	3/8	3.32	5 7/16	6 1/4	4 7/8	2 5/8
5	5.8	1 13/16	1/2-20	5 1/2	1/2	5/8	9/16	1 3/4	1 1/4	7/16	4.10	6 5/8	7 5/8	5 1/8	2 7/8
6	6.9	1 13/16	1/2-20	6 1/2	3/4	3/4	9/16	2	1 1/2	7/16	4.88	7 5/8	8 5/8	5 3/4	3 1/8

* Cushions not available on 1" bore.

** On 1", 1 1/2", 2" and 2 1/2" bore sizes, the head-end (only) pipe thread is not full depth on cylinders with No. 2 rods. Minimum of three full threads available.

■ 1" bore head dimension is 1 3/4" x 1 1/2". See page 12.

Table 2—Rod Dimensions

Bore	Rod No.	Rod Dia. MM	Thread		Rod Extensions and Pilot Dimensions								Add Stroke				
			Style 8 CC	Style 4 & 9 KK	A	+ .000 - .002 B	C	D	LA	NA	V	W	WF	Y	XF	ZB	ZF
1	1(Std.)	1/2	7/16-20	5/16-24	5/8	.999	3/8	3/8	1 1/4	7/16	1/4	5/8	1	1 15/16	4 1/2	4 11/16	4 7/8
	2	5/8	1/2-20	7/16-20	3/4	1.124	3/8	1/2	1 3/8	9/16	1/4	5/8	1	1 15/16	4 1/2	4 11/16	4 7/8
1 1/2	1(Std.)	5/8	1/2-20	7/16-20	3/4	1.124	3/8	1/2	1 3/8	9/16	1/4	5/8	1	1 15/16	4 5/8	4 7/8	5
	2	1	7/8-14	3/4-16	1 1/8	1.499	1/2	7/8	2 1/8	15/16	1/2	1	1 3/8	2 5/16	5	5 1/4	5 3/8
2	1(Std.)	5/8	1/2-20	7/16-20	3/4	1.124	3/8	1/2	1 3/8	9/16	1/4	5/8	1	1 15/16	4 5/8	4 5/8	5
	2	1 3/8	1 1/4-12	1-14	1 5/8	1.999	5/8	1 1/8	2 7/8	1 5/16	5/8	1 1/4	1 5/8	2 9/16	5 1/4	5 5/16	5 5/8
	3	1	7/8-14	3/4-16	1 1/8	1.499	1/2	7/8	2 1/8	1 5/16	1/2	1	1 3/8	2 5/16	5	5 5/16	5 3/8
2 1/2	1(Std.)	5/8	1/2-20	7/16-20	3/4	1.124	3/8	1/2	1 3/8	9/16	1/4	5/8	1	1 15/16	4 3/4	5 1/16	5 1/8
	2	1 3/4	1 1/2-12	1 1/4-12	2	2.374	3/4	1 1/2	3 1/2	1 11/16	3/4	1 1/2	1 7/8	2 13/16	5 5/8	5 5/16	6
	3	1	7/8-14	3/4-16	1 1/8	1.499	1/2	7/8	2 1/8	1 5/16	1/2	1	1 3/8	2 5/16	5 1/8	5 7/16	5 1/2
	4	1 3/8	1 1/4-12	1-14	1 5/8	1.999	5/8	1 1/8	2 7/8	1 5/16	5/8	1 1/4	1 5/8	2 9/16	5 3/8	5 11/16	5 3/4
3 1/4	1(Std.)	1	7/8-14	3/4-16	1 1/8	1.499	1/2	7/8	1 7/8	1 5/16	1/4	3/4	1 3/8	2 7/16	5 5/8	6	6 1/4
	2	2	1 3/4-12	1 1/2-12	2 1/4	2.624	7/8	1 11/16	3 5/8	1 5/16	1/2	1 3/8	2	3 1/16	6 1/4	6 5/8	6 7/8
	3	1 3/8	1 1/4-12	1-14	1 5/8	1.999	5/8	1 1/8	2 5/8	1 5/16	3/8	1	1 5/8	2 11/16	5 7/8	6 1/4	6 1/2
	4	1 3/4	1 1/2-12	1 1/4-12	2	2.374	3/4	1 1/2	3 1/4	1 11/16	1/2	1 1/4	1 7/8	2 15/16	6 1/8	6 1/2	6 3/4
4	1(Std.)	1	7/8-14	3/4-16	1 1/8	1.499	1/2	7/8	1 7/8	1 5/16	1/4	3/4	1 3/8	2 7/16	5 5/8	6	6 1/4
	2	2 1/2	2 1/4-12	1 7/8-12	3	3.124	1	2 1/16	4 5/8	2 3/8	5/8	1 5/8	2 1/4	3 5/16	6 1/2	6 7/8	7 1/8
	3	1 3/8	1 1/4-12	1-14	1 5/8	1.999	5/8	1 1/8	2 5/8	1 5/16	3/8	1	1 5/8	2 11/16	5 7/8	6 1/4	6 1/2
	4	1 3/4	1 1/2-12	1 1/4-12	2	2.374	3/4	1 1/2	3 1/4	1 11/16	1/2	1 1/4	1 7/8	2 15/16	6 1/8	6 1/2	6 3/4
	5	2	1 3/4-12	1 1/2-12	2 1/4	2.624	7/8	1 11/16	3 5/8	1 5/16	1/2	1 3/8	2	3 1/16	6 1/4	6 5/8	6 7/8
5	1(Std.)	1	7/8-14	3/4-16	1 1/8	1.499	1/2	7/8	1 7/8	1 5/16	1/4	3/4	1 3/8	2 7/16	5 5/8	6	6 1/4
	2	3 1/2	3 1/4-12	2 1/2-12	3 1/2	4.249	1	3	5 1/8	3 3/8	5/8	1 5/8	2 1/4	3 5/16	6 3/4	7 3/16	7 3/8
	3	1 3/8	1 1/4-12	1-14	1 5/8	1.999	5/8	1 1/8	2 5/8	1 5/16	3/8	1	1 5/8	2 11/16	6 1/8	6 9/16	6 3/4
	4	1 3/4	1 1/2-12	1 1/4-12	2	2.374	3/4	1 1/2	3 1/4	1 11/16	1/2	1 1/4	1 7/8	2 15/16	6 3/8	6 13/16	7
	5	2	1 3/4-12	1 1/2-12	2 1/4	2.624	7/8	1 11/16	3 5/8	1 5/16	1/2	1 3/8	2	3 1/16	6 1/2	6 15/16	7 1/8
	6	2 1/2	2 1/4-12	1 7/8-12	3	3.124	1	2 1/16	4 5/8	2 3/8	5/8	1 5/8	2 1/4	3 5/16	6 3/4	7 3/16	7 3/8
	7	3	2 3/4-12	2 1/4-12	3 1/2	3.749	1	2 5/8	5 1/8	2 7/8	5/8	1 5/8	2 1/4	3 5/16	6 3/4	7 3/16	7 3/8
6	1(Std.)	1 3/8	1 1/4-12	1-14	1 5/8	1.999	5/8	1 1/8	2 1/2	1 5/16	1/4	7/8	1 5/8	2 13/16	6 5/8	7 1/16	7 3/8
	2	4	3 3/4-12	3-12	4	4.749	1	3 3/8	5 1/2	3 7/8	1/2	1 1/2	2 1/4	3 7/16	7 1/4	7 11/16	8
	3	1 3/4	1 1/2-12	1 1/4-12	2	2.374	3/4	1 1/2	3 1/8	1 11/16	3/8	1 1/8	1 7/8	3 1/16	6 7/8	7 5/16	7 5/8
	4	2	1 3/4-12	1 1/2-12	2 1/4	2.624	7/8	1 11/16	3 1/2	1 5/16	3/8	1 1/4	2	3 3/16	7	7 7/16	7 3/4
	5	2 1/2	2 1/4-12	1 7/8-12	3	3.124	1	2 1/16	4 1/2	2 3/8	1/2	1 1/2	2 1/4	3 7/16	7 1/4	7 11/16	8
	6	3	2 3/4-12	2 1/4-12	3 1/2	3.749	1	2 5/8	5	2 7/8	1/2	1 1/2	2 1/4	3 7/16	7 1/4	7 11/16	8
	7	3 1/2	3 1/4-12	2 1/2-12	3 1/2	4.249	1	3	5	3 3/8	1/2	1 1/2	2 1/4	3 7/16	7 1/4	7 11/16	8

Table 3 — Envelope and Mounting Dimensions



Head Square Flange
Style JB
(NFPA Style MF5)

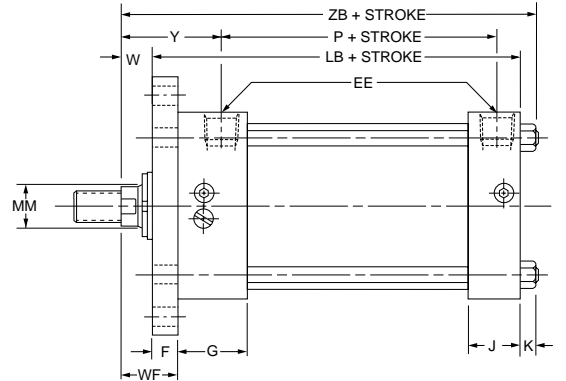
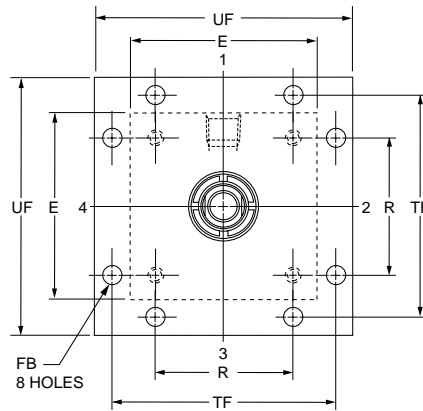
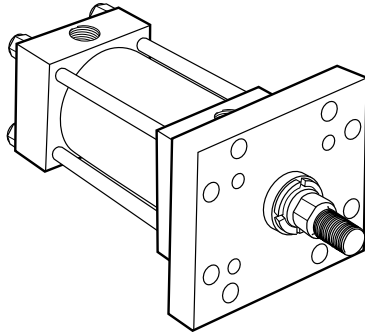

Cap Square Flange
Style HB
(NFPA Style MF6)

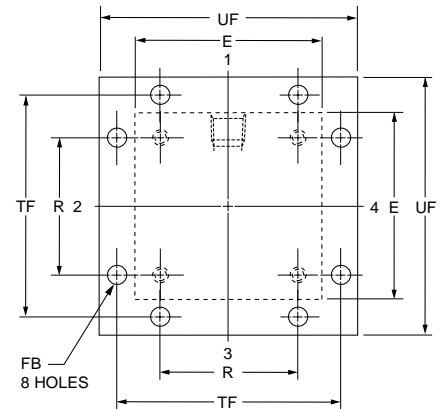
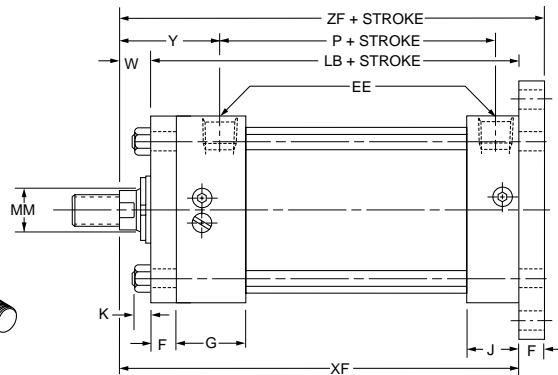
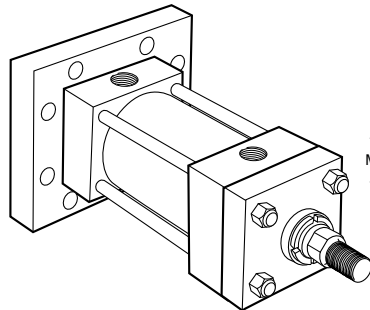

Rod End Dimensions — see table 2

Thread Style 4
(NFPA Style SM)
Small Male

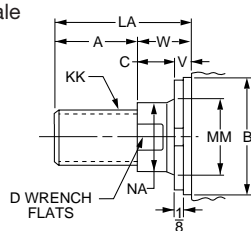

A high strength rod end stud is supplied on thread style 4 through 2" diameter rods. Larger sizes or special rod ends are cut threads. Style 4 rod ends are recommended where the workpiece is secured against the rod shoulder. When the workpiece is not shouldered, style 4 rod

Thread Style 8
(NFPA Style IM)
Intermediate Male

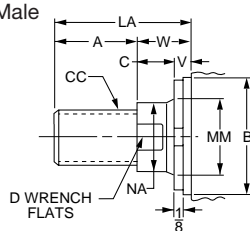

ends are recommended through 2" piston rod diameters and style 8 rod ends are recommended on larger diameters. Use style 9 for applications where female rod end threads are required. If rod end is not specified, style 4 will be supplied.

Thread Style 9
(NFPA Style SF)
Small Female

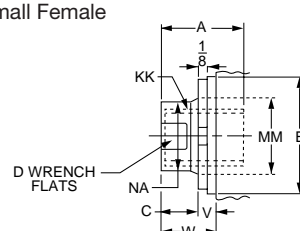

"Special" Thread Style 3

Special thread, extension, rod eye, blank, etc., are also available.

To order, specify "Style 3" and give desired dimensions for KK, A and W or WF. If otherwise special, furnish dimensioned sketch.

Table 1—Envelope and Mounting Dimensions

Bore	E	EE NPTF	F	FB	G	J	K	R	TF	UF	Add Stroke	
											LB	P
1*	■	1/4	3/8	1/4	1 1/2	1	3/16	1.08	2	2 1/2	3 7/8	2 1/8
1 1/2	2	3/8**	3/8	5/16	1 1/2	1	1/4	1.43	2 3/4	3 3/8	4	2 1/4
2	2 1/2	3/8**	3/8	3/8	1 1/2	1	5/16	1.84	3 3/8	4 1/8	4	2 1/4
2 1/2	3	3/8**	3/8	3/8	1 1/2	1	5/16	2.19	3 7/8	4 5/8	4 1/8	2 3/8
3 1/4	3 3/4	1/2	5/8	7/16	1 3/4	1 1/4	3/8	2.76	4 11/16	5 1/2	4 7/8	2 5/8
4	4 1/2	1/2	5/8	7/16	1 3/4	1 1/4	3/8	3.32	5 7/16	6 1/4	4 7/8	2 5/8
5	5 1/2	1/2	5/8	9/16	1 3/4	1 1/4	7/16	4.10	6 5/8	7 5/8	5 1/8	2 7/8
6	6 1/2	3/4	3/4	9/16	2	1 1/2	7/16	4.88	7 5/8	8 5/8	5 3/4	3 1/8

* Cushions not available on 1" bore.

** On 1", 1 1/2", 2" and 2 1/2" bore sizes, the head-end (only) pipe thread is not full depth on cylinders with No. 2 rods. Minimum of three full threads available.

■ 1" bore head dimension is 1 3/4" x 1 1/2". See page 12.

Table 2—Rod Dimensions

Bore	Rod No.	Rod Dia. MM	Thread		Rod Extensions and Pilot Dimensions								Add Stroke				
			Style 8 CC	Style 4 & 9 KK	A	+0.000 -0.002 B	C	D	LA	NA	V	W	WF	Y	XF	ZB	ZF
1	1(Std.)	1/2	7/16-20	5/16-24	5/8	.999	3/8	3/8	1 1/4	7/16	1/4	5/8	1	1 15/16	4 1/2	4 11/16	4 7/8
	2	5/8	1/2-20	7/16-20	3/4	1.124	3/8	1/2	1 3/8	9/16	1/4	5/8	1	1 15/16	4 1/2	4 11/16	4 7/8
1 1/2	1(Std.)	5/8	1/2-20	7/16-20	3/4	1.124	3/8	1/2	1 3/8	9/16	1/4	5/8	1	1 15/16	4 5/8	4 7/8	5
	2	1	7/8-14	3/4-16	1 1/8	1.499	1/2	7/8	2 1/8	15/16	1/2	1	1 3/8	2 5/16	5	5 1/4	5 3/8
2	1(Std.)	5/8	1/2-20	7/16-20	3/4	1.124	3/8	1/2	1 3/8	9/16	1/4	5/8	1	1 15/16	4 5/8	4 15/16	5
	2	1 3/8	1 1/4-12	1-14	1 5/8	1.999	5/8	1 1/8	2 7/8	1 5/16	5/8	1 1/4	1 5/8	2 9/16	5 1/4	5 5/16	5 5/8
	3	1	7/8-14	3/4-16	1 1/8	1.499	1/2	7/8	2 1/8	1 5/16	1/2	1	1 3/8	2 5/16	5	5 5/16	5 3/8
2 1/2	1(Std.)	5/8	1/2-20	7/16-20	3/4	1.124	3/8	1/2	1 3/8	9/16	1/4	5/8	1	1 15/16	4 3/4	5 1/8	5 1/8
	2	1 3/4	1 1/2-12	1 1/4-12	2	2.374	3/4	1 1/2	3 1/2	1 11/16	3/4	1 1/2	1 7/8	2 13/16	5 5/8	5 15/16	6
	3	1	7/8-14	3/4-16	1 1/8	1.499	1/2	7/8	2 1/8	1 5/16	1/2	1	1 3/8	2 5/16	5 1/8	5 7/16	5 1/2
	4	1 3/8	1 1/4-12	1-14	1 5/8	1.999	5/8	1 1/8	2 7/8	1 5/16	5/8	1 1/4	1 5/8	2 9/16	5 3/8	5 11/16	5 3/4
3 1/4	1(Std.)	1	7/8-14	3/4-16	1 1/8	1.499	1/2	7/8	1 7/8	1 5/16	1/4	3/4	1 3/8	2 7/16	5 5/8	6	6 1/4
	2	2	1 3/4-12	1 1/2-12	2 1/4	2.624	7/8	1 11/16	3 5/8	1 5/16	1/2	1 3/8	2	3 1/16	6 1/4	6 5/8	6 7/8
	3	1 3/8	1 1/4-12	1-14	1 5/8	1.999	5/8	1 1/8	2 5/8	1 5/16	3/8	1	1 5/8	2 11/16	5 7/8	6 1/4	6 1/2
	4	1 3/4	1 1/2-12	1 1/4-12	2	2.374	3/4	1 1/2	3 1/4	1 11/16	1/2	1 1/4	1 7/8	2 15/16	6 1/8	6 1/2	6 3/4
4	1(Std.)	1	7/8-14	3/4-16	1 1/8	1.499	1/2	7/8	1 7/8	1 5/16	1/4	3/4	1 3/8	2 7/16	5 5/8	6	6 1/4
	2	2 1/2	2 1/4-12	1 7/8-12	3	3.124	1	2 1/16	4 5/8	2 3/8	5/8	1 5/8	2 1/4	3 5/16	6 1/2	6 7/8	7 1/8
	3	1 3/8	1 1/4-12	1-14	1 5/8	1.999	5/8	1 1/8	2 5/8	1 5/16	3/8	1	1 5/8	2 11/16	5 7/8	6 1/4	6 1/2
	4	1 3/4	1 1/2-12	1 1/4-12	2	2.374	3/4	1 1/2	3 1/4	1 11/16	1/2	1 1/4	1 7/8	2 15/16	6 1/8	6 1/2	6 3/4
	5	2	1 3/4-12	1 1/2-12	2 1/4	2.624	7/8	1 11/16	3 5/8	1 5/16	1/2	1 3/8	2	3 1/16	6 1/4	6 5/8	6 7/8
5	1(Std.)	1	7/8-14	3/4-16	1 1/8	1.499	1/2	7/8	1 7/8	1 5/16	1/4	3/4	1 3/8	2 7/16	5 7/8	6 5/16	6 1/2
	2	3 1/2	3 1/4-12	2 1/2-12	3 1/2	4.249	1	3	5 1/8	3 3/8	5/8	1 5/8	2 1/4	3 5/16	6 3/4	7 3/16	7 3/8
	3	1 3/8	1 1/4-12	1-14	1 5/8	1.999	5/8	1 1/8	2 5/8	1 5/16	3/8	1	1 5/8	2 11/16	6 1/8	6 9/16	6 3/4
	4	1 3/4	1 1/2-12	1 1/4-12	2	2.374	3/4	1 1/2	3 1/4	1 11/16	1/2	1 1/4	1 7/8	2 15/16	6 3/8	6 13/16	7
	5	2	1 3/4-12	1 1/2-12	2 1/4	2.624	7/8	1 11/16	3 5/8	1 5/16	1/2	1 3/8	2	3 1/16	6 1/2	6 15/16	7 1/8
	6	2 1/2	2 1/4-12	1 7/8-12	3	3.124	1	2 1/16	4 5/8	2 3/8	5/8	1 5/8	2 1/4	3 5/16	6 3/4	7 3/16	7 3/8
	7	3	2 3/4-12	2 1/4-12	3 1/2	3.749	1	2 5/8	5 1/8	2 7/8	5/8	1 5/8	2 1/4	3 5/16	6 3/4	7 3/16	7 3/8
6	1(Std.)	1 3/8	1 1/4-12	1-14	1 5/8	1.999	5/8	1 1/8	2 1/2	1 5/16	1/4	7/8	1 5/8	2 13/16	6 5/8	7 1/16	7 3/8
	2	4	3 3/4-12	3-12	4	4.749	1	3 3/8	5 1/2	3 7/8	1/2	1 1/2	2 1/4	3 7/16	7 1/4	7 11/16	8
	3	1 3/4	1 1/2-12	1 1/4-12	2	2.374	3/4	1 1/2	3 1/8	1 11/16	3/8	1 1/8	1 7/8	3 1/16	6 7/8	7 5/16	7 5/8
	4	2	1 3/4-12	1 1/2-12	2 1/4	2.624	7/8	1 11/16	3 1/2	1 5/16	3/8	1 1/4	2	3 3/16	7	7 7/16	7 3/4
	5	2 1/2	2 1/4-12	1 7/8-12	3	3.124	1	2 1/16	4 1/2	2 3/8	1/2	1 1/2	2 1/4	3 7/16	7 1/4	7 11/16	8
	6	3	2 3/4-12	2 1/4-12	3 1/2	3.749	1	2 5/8	5	2 7/8	1/2	1 1/2	2 1/4	3 7/16	7 1/4	7 11/16	8
	7	3 1/2	3 1/4-12	2 1/2-12	3 1/2	4.249	1	3	5	3 3/8	1/2	1 1/2	2 1/4	3 7/16	7 1/4	7 11/16	8

Table 3 — Envelope and Mounting Dimensions

Side Lug
Style C
(NFPA Style MS2)

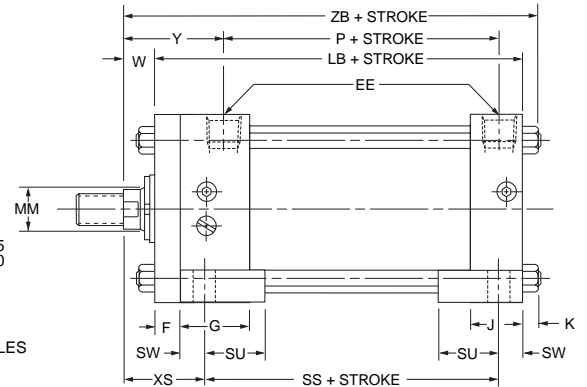
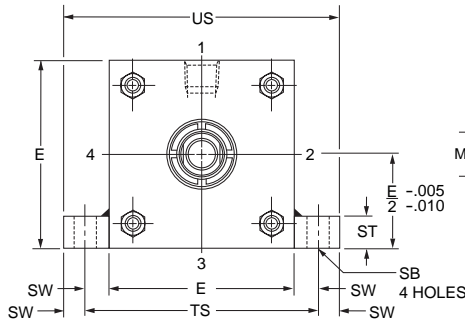
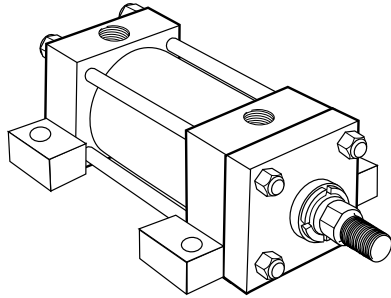

Side Tapped
Style F
(NFPA Style MS4)

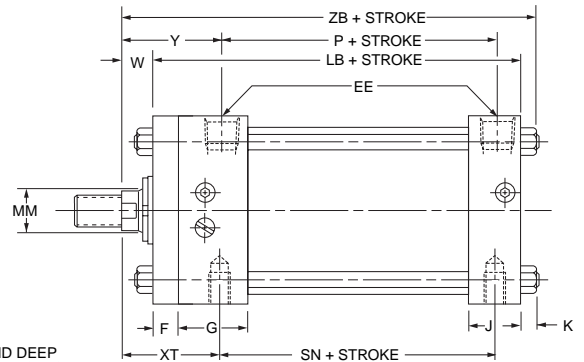
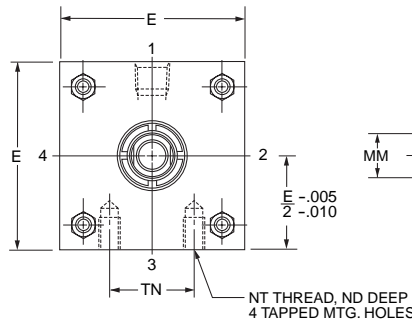
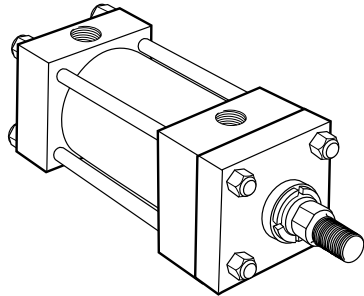

Rod End Dimensions — see table 2

Thread Style 4
(NFPA Style SM)
Small Male

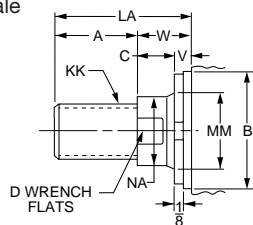

A high strength rod end stud is supplied on thread style 4 through 2" diameter rods. Larger sizes or special rod ends are cut threads. Style 4 rod ends are recommended where the workpiece is secured against the rod shoulder. When the workpiece is not shouldered, style 4 rod

Thread Style 8
(NFPA Style IM)
Intermediate Male

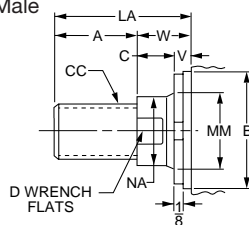

ends are recommended through 2" piston rod diameters and style 8 rod ends are recommended on larger diameters. Use style 9 for applications where female rod end threads are required. If rod end is not specified, style 4 will be supplied.

Thread Style 9
(NFPA Style SF)
Small Female

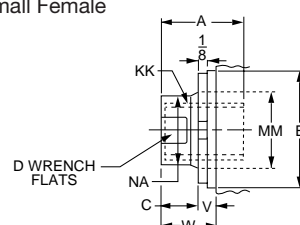

"Special" Thread Style 3

Special thread, extension, rod eye, blank, etc., are also available.

To order, specify "Style 3" and give desired dimensions for KK, A and W or WF. If otherwise special, furnish dimensioned sketch.

Table 1—Envelope and Mounting Dimensions

Bore	E	EE NPTF	F	G	J	K	NT	SB•	ST	SU	SW	TN	TS	US	Add Stroke			
															LB	P	SN	SS
1*	■	1/4	3/8	1 1/2	1	3/16	10-24	9/32	5/16	3/4	5/16	9/16	2 1/8	2 3/4	3 7/8	2 1/8	2 1/8	2 7/8
1 1/2	2	3/8**	3/8	1 1/2	1	1/4	1/4-20	7/16	1/2	15/16	3/8	5/8	2 3/4	3 1/2	4	2 1/4	2 1/4	2 7/8
2	2 1/2	3/8**	3/8	1 1/2	1	5/16	5/16-18	7/16	1/2	15/16	3/8	7/8	3 1/4	4	4	2 1/4	2 1/4	2 7/8
2 1/2	3	3/8**	3/8	1 1/2	1	5/16	3/8-16	7/16	1/2	15/16	3/8	1 1/4	3 3/4	4 1/2	4 1/8	2 3/8	2 3/8	3
3 1/4	3 3/4	1/2	5/8	1 3/4	1 1/4	3/8	1/2-13	9/16	3/4	1 1/4	1/2	1 1/2	4 3/4	5 3/4	4 7/8	2 5/8	2 5/8	3 1/4
4	4 1/2	1/2	5/8	1 3/4	1 1/4	3/8	1/2-13	9/16	3/4	1 1/4	1/2	2 1/16	5 1/2	6 1/2	4 7/8	2 5/8	2 5/8	3 1/4
5	5 1/2	1/2	5/8	1 3/4	1 1/4	7/16	5/8-11	13/16	1	1 9/16	1 1/16	2 11/16	6 7/8	8 1/4	5 1/8	2 7/8	2 7/8	3 1/8
6	6 1/2	3/4	3/4	2	1 1/2	7/16	3/4-10	13/16	1	1 9/16	1 1/16	3 1/4	7 7/8	9 1/4	5 3/4	3 1/8	3 1/8	3 5/8

* Cushions not available on 1" bore.

** On 1", 1 1/2", 2" and 2 1/2" bore sizes, the head-end (only) pipe thread is not full depth on cylinders with No. 2 rods. Minimum of three full threads available.

• Upper surface spot-faced for socket head screws.

■ 1" bore head dimension is 1 3/4" x 1 1/2". See page 12.

Table 2—Rod Dimensions

Bore	Rod No.	Rod Dia. MM	Thread		Rod Extensions and Pilot Dimensions								ND	XS	XT	Y	Add Stroke ZB
			Style 8 CC	Style 4 & 9 KK	A	+ .000 - .002 B	C	D	LA	NA	V	W					
1	1(Std.)	1/2	7/16-20	7/16-24	5/8	.999	3/8	3/8	1 1/4	7/16	1/4	5/8	1/4	15/16	1 15/16	1 15/16	4 11/16
	2	5/8	1/2-20	7/16-20	3/4	1.124	3/8	1/2	1 3/8	9/16	1/4	5/8	1/4	15/16	1 15/16	1 15/16	4 11/16
1 1/2	1(Std.)	5/8	1/2-20	7/16-20	3/4	1.124	3/8	1/2	1 3/8	9/16	1/4	5/8	5/16	1 3/8	1 15/16	1 15/16	4 7/8
	2	1	7/8-14	3/4-16	1 1/8	1.499	1/2	7/8	2 1/8	15/16	1/2	1	5/16	1 3/4	2 5/16	2 5/16	5 1/4
2	1(Std.)	5/8	1/2-20	7/16-20	3/4	1.124	3/8	1/2	1 3/8	9/16	1/4	5/8	11/32	1 3/8	1 15/16	1 15/16	4 15/16
	2	1 3/8	1 1/4-12	1-14	1 5/8	1.999	5/8	1 1/8	2 7/8	1 5/16	5/8	1 1/4	11/32	2	2 9/16	2 9/16	5 9/16
	3	1	7/8-14	3/4-16	1 1/8	1.499	1/2	7/8	2 1/8	1 5/16	1/2	1	11/32	1 3/4	2 5/16	2 5/16	5 5/16
2 1/2	1(Std.)	5/8	1/2-20	7/16-20	3/4	1.124	3/8	1/2	1 3/8	9/16	1/4	5/8	7/16	1 3/8	1 15/16	1 15/16	5 1/16
	2	1 3/4	1 1/2-12	1 1/4-12	2	2.374	3/4	1 1/2	3 1/2	1 11/16	3/4	1 1/2	7/16	2 1/4	2 13/16	2 13/16	5 5/16
	3	1	7/8-14	3/4-16	1 1/8	1.499	1/2	7/8	2 1/8	1 5/16	1/2	1	7/16	1 3/4	2 5/16	2 5/16	5 7/16
3 1/4	1(Std.)	1	7/8-14	3/4-16	1 1/8	1.499	1/2	7/8	1 7/8	1 5/16	1/4	3/4	7/16	2	2 9/16	2 9/16	5 11/16
	2	2	1 3/4-12	1 1/2-12	2 1/4	2.624	7/8	1 1/8	3 5/8	1 15/16	1/2	1 3/8	1/2	2 1/2	3 1/16	3 1/16	6
	3	1 3/8	1 1/4-12	1-14	1 5/8	1.999	5/8	1 1/8	2 5/8	1 5/16	3/8	1	1/2	2 1/8	2 11/16	2 11/16	6 1/4
4	1(Std.)	1	7/8-14	3/4-16	1 1/8	1.499	1/2	7/8	1 7/8	1 5/16	1/4	3/4	5/8	1 7/8	2 7/16	2 7/16	6
	2	2 1/2	2 1/4-12	1 7/8-12	3	3.124	1	2 1/16	4 5/8	2 3/8	5/8	1 5/8	5/8	2 3/4	3 5/16	3 5/16	6 7/8
	3	1 3/8	1 1/4-12	1-14	1 5/8	1.999	5/8	1 1/8	2 5/8	1 5/16	3/8	1	5/8	2 1/8	2 11/16	2 11/16	6 1/4
5	1(Std.)	1	7/8-14	3/4-16	1 1/8	1.499	1/2	7/8	1 7/8	1 5/16	1/4	3/4	5/8	1 7/8	2 7/16	2 7/16	6 5/16
	2	3 1/2	3 1/4-12	2 1/2-12	3 1/2	4.249	1	3	5 1/8	3 3/8	5/8	1 5/8	3/4	2 15/16	3 5/16	3 5/16	7 3/16
	3	1 3/8	1 1/4-12	1-14	1 5/8	1.999	5/8	1 1/8	2 5/8	1 5/16	3/8	1	3/4	2 5/16	2 11/16	2 11/16	6 9/16
	4	1 3/4	1 1/2-12	1 1/4-12	2	2.374	3/4	1 1/2	3 1/4	1 11/16	1/2	1 1/4	3/4	2 9/16	2 15/16	2 15/16	6 13/16
	5	2	1 3/4-12	1 1/2-12	2 1/4	2.624	7/8	1 1/8	3 5/8	1 15/16	1/2	1 3/8	3/4	2 11/16	3 1/16	3 1/16	6 15/16
	6	2 1/2	2 1/4-12	1 7/8-12	3	3.124	1	2 1/16	4 5/8	2 3/8	5/8	1 5/8	3/4	2 15/16	3 5/16	3 5/16	7 3/16
	7	3	2 3/4-12	2 1/4-12	3 1/2	3.749	1	2 5/8	5 1/8	2 7/8	5/8	1 5/8	3/4	2 15/16	3 5/16	3 5/16	7 3/16
6	1(Std.)	1 3/8	1 1/4-12	1-14	1 5/8	1.999	5/8	1 1/8	2 1/2	1 5/16	1/4	7/8	7/8	2 5/16	2 13/16	2 13/16	7 1/16
	2	4	3 3/4-12	3-12	4	4.749	1	3 3/8	5 1/2	3 7/8	1/2	1 1/2	7/8	2 15/16	3 7/16	3 7/16	7 11/16
	3	1 3/4	1 1/2-12	1 1/4-12	2	2.374	3/4	1 1/2	3 1/8	1 11/16	3/8	1 1/8	7/8	2 9/16	3 1/16	3 1/16	7 5/16
	4	2	1 3/4-12	1 1/2-12	2 1/4	2.624	7/8	1 1/16	3 1/2	1 15/16	3/8	1 1/4	7/8	2 11/16	3 3/16	3 3/16	7 7/16
	5	2 1/2	2 1/4-12	1 7/8-12	3	3.124	1	2 1/16	4 1/2	2 3/8	1/2	1 1/2	7/8	2 15/16	3 7/16	3 7/16	7 11/16
	6	3	2 3/4-12	2 1/4-12	3 1/2	3.749	1	2 5/8	5	2 7/8	1/2	1 1/2	7/8	2 15/16	3 7/16	3 7/16	7 11/16

Table 3 — Envelope and Mounting Dimensions

Head Trunnion
Style D
(NFFPA Style MT1)

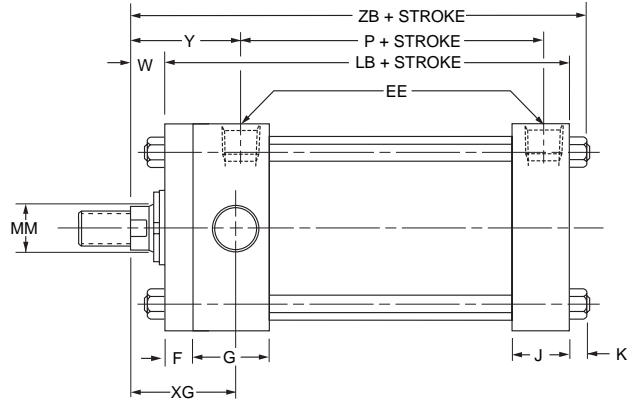
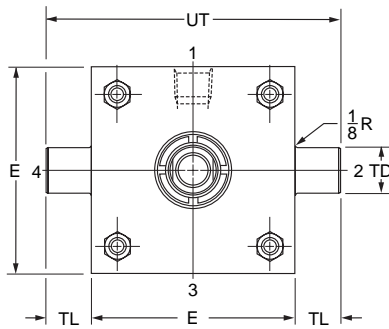
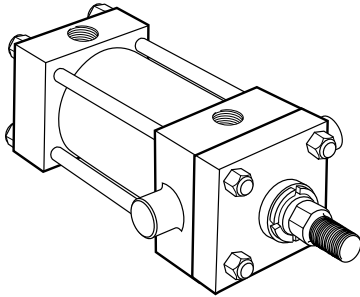

Cap Trunnion
Style DB
(NFFPA Style MT2)

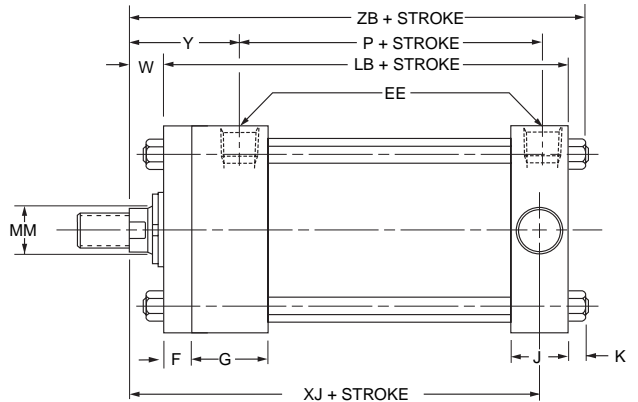
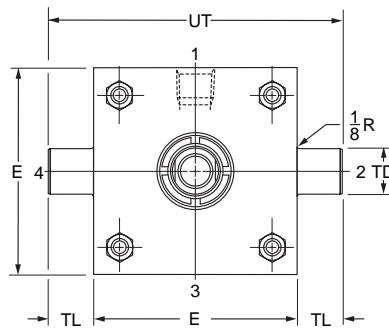
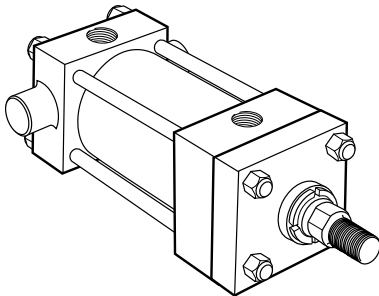

Intermediate Fixed Trunnion
Style DD
(NFFPA Style MT4)

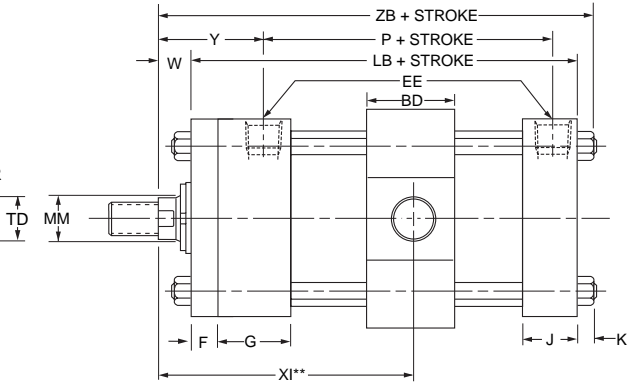
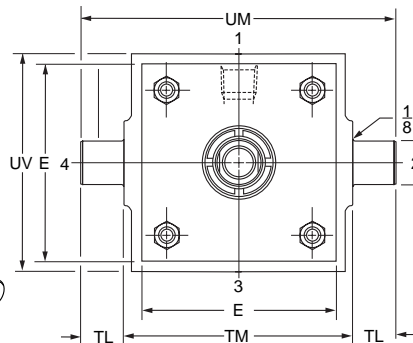
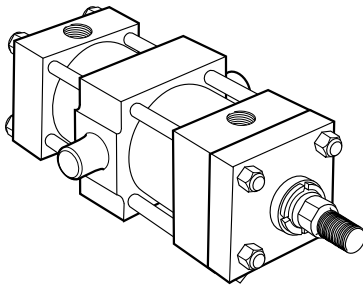

Rod End Dimensions — see table 2

Thread Style 4
(NFFPA Style SM)
Small Male

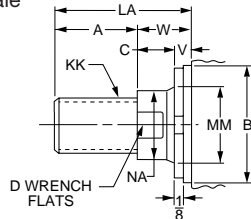

A high strength rod end stud is supplied on thread style 4 through 2" diameter rods. Larger sizes or special rod ends are cut threads. Style 4 rod ends are recommended where the workpiece is secured against the rod shoulder. When the workpiece is not shouldered, style 4 rod

Thread Style 8
(NFFPA Style IM)
Intermediate Male

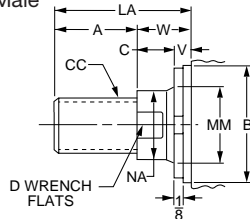

ends are recommended through 2" piston rod diameters and style 8 rod ends are recommended on larger diameters. Use style 9 for applications where female rod end threads are required. If rod end is not specified, style 4 will be supplied.

Thread Style 9
(NFFPA Style SF)
Small Female

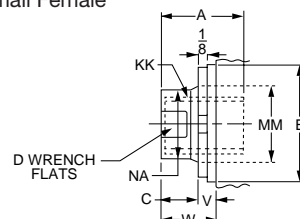

"Special" Thread Style 3

Special thread, extension, rod eye, blank, etc., are also available.

To order, specify "Style 3" and give desired dimensions for KK, A and W or WF. If otherwise special, furnish dimensioned sketch.

Table 1—Envelope and Mounting Dimensions

Bore	BD	E	EE NPTF	F	G	J	K	+.000 TD -.001	TL	TM	UM	UT	UV	Add Stroke		Style DD Min. Stroke
														LB	P	
1*	•	■	1/4	3/8	1 1/2	1	3/16	.750	3/4	•	•	3	•	3 7/8	2 1/8	•
1 1/2	1 1/4	2	3/8**	3/8	1 1/2	1	1/4	1.000	1	2 1/2	4 1/2	4	2 1/2	4	2 1/4	1/4
2	1 1/2	2 1/2	3/8**	3/8	1 1/2	1	5/16	1.000	1	3	5	4 1/2	3	4	2 1/4	1/2
2 1/2	1 1/2	3	3/8**	3/8	1 1/2	1	5/16	1.000	1	3 1/2	5 1/2	5	3 1/2	4 1/8	2 3/8	3/8
3 1/4	2	3 3/4	1/2	5/8	1 3/4	1 1/4	3/8	1.000	1	4 1/2	6 1/2	5 3/4	4 1/4	4 7/8	2 5/8	7/8
4	2	4 1/2	1/2	5/8	1 3/4	1 1/4	3/8	1.000	1	5 1/4	7 1/4	6 1/2	5	4 7/8	2 5/8	7/8
5	2	5 1/2	1/2	5/8	1 3/4	1 1/4	7/16	1.000	1	6 1/4	8 1/4	7 1/2	6	5 1/8	2 7/8	5/8
6	2 1/2	6 1/2	3/4	3/4	2	1 1/2	7/16	1.375	1 3/8	7 5/8	10 3/8	9 1/4	7	5 3/4	3 1/8	1 1/8

* Cushions not available on 1" bore.

** On 1", 1 1/2", 2" and 2 1/2" bore sizes, the head-end (only) pipe thread is not full depth on cylinders with No. 2 rods. Minimum of three full threads available.

• Mounting style not available in 1" bore.

■ 1" bore head dimension is 1 3/4" x 1 1/2". See page 12.

Table 2—Rod Dimensions

Bore	Rod No.	Rod Dia. MM	Thread		Rod Extensions and Pilot Dimensions								XG	Min.** XI	Y	Add Stroke	
			Style 8 CC	Style 4 & 9 KK	A	+0.000 -.002 B	C	D	LA	NA	V	W				XJ	ZB
1	1(Std.)	1/2	7/16-20	5/16-24	5/8	.999	3/8	3/8	1 1/4	7/16	1/4	5/8	1 3/4	*	1 15/16	4	4 11/16
	2	5/8	1/2-20	7/16-20	3/4	1.124	3/8	1/2	1 3/8	9/16	1/4	5/8	1 3/4	*	1 15/16	4	4 11/16
1 1/2	1(Std.)	5/8	1/2-20	7/16-20	3/4	1.124	3/8	1/2	1 3/8	9/16	1/4	5/8	1 3/4	3 3/16	1 15/16	4 1/8	4 7/8
	2	1	7/8-14	3/4-16	1 1/8	1.499	1/2	7/8	2 1/8	1 5/16	1/2	1	2 1/8	3 3/16	2 5/16	4 1/2	5 1/4
2	1(Std.)	5/8	1/2-20	7/16-20	3/4	1.124	3/8	1/2	1 3/8	9/16	1/4	5/8	1 3/4	3 5/16	1 15/16	4 1/8	4 5/16
	2	1 3/8	1 1/4-12	1-14	1 5/8	1.999	5/8	1 1/8	2 7/8	1 5/16	5/8	1 1/4	2 3/8	3 15/16	2 9/16	4 3/4	5 9/16
	3	1	7/8-14	3/4-16	1 1/8	1.499	1/2	7/8	2 1/8	1 5/16	1/2	1	2 1/8	3 11/16	2 5/16	4 1/2	5 5/16
2 1/2	1(Std.)	5/8	1/2-20	7/16-20	3/4	1.124	3/8	1/2	1 3/8	9/16	1/4	5/8	1 3/4	3 5/16	1 15/16	4 1/8	5 1/16
	2	1 3/4	1 1/2-12	1 1/4-12	2	2.374	3/4	1 1/2	3 1/2	1 11/16	3/4	1 1/2	2 5/8	4 3/16	2 13/16	5 1/8	5 5/16
	3	1	7/8-14	3/4-16	1 1/8	1.499	1/2	7/8	2 1/8	1 5/16	1/2	1	2 1/8	3 11/16	2 5/16	4 5/8	5 7/16
3 1/4	1(Std.)	1	7/8-14	3/4-16	1 1/8	1.499	1/2	7/8	1 7/8	1 5/16	1/4	3/4	2 1/4	4 3/16	2 7/16	5	6
	2	2	1 3/4-12	1 1/2-12	2 1/4	2.624	7/8	1 11/16	3 5/8	1 5/16	1/2	1 3/8	2 7/8	4 13/16	3 1/16	5 5/8	6 5/8
	3	1 3/8	1 1/4-12	1-14	1 5/8	1.999	5/8	1 1/8	2 5/8	1 5/16	3/8	1	2 1/2	4 7/16	2 11/16	5 1/4	6 1/4
	4	1 3/4	1 1/2-12	1 1/4-12	2	2.374	3/4	1 1/2	3 1/4	1 11/16	1/2	1 1/4	2 3/4	4 11/16	2 15/16	5 1/2	6 1/2
4	1(Std.)	1	7/8-14	3/4-16	1 1/8	1.499	1/2	7/8	1 7/8	1 5/16	1/4	3/4	2 1/4	4 3/16	2 7/16	5	6
	2	2 1/2	2 1/4-12	1 7/8-12	3	3.124	1	2 1/16	4 5/8	2 3/8	5/8	1 5/8	3 1/8	5 1/16	3 5/16	5 7/8	6 7/8
	3	1 3/8	1 1/4-12	1-14	1 5/8	1.999	5/8	1 1/8	2 5/8	1 5/16	3/8	1	2 1/2	4 7/16	2 11/16	5 1/4	6 1/4
	4	1 3/4	1 1/2-12	1 1/4-12	2	2.374	3/4	1 1/2	3 1/4	1 11/16	1/2	1 1/4	2 3/4	4 11/16	2 15/16	5 1/2	6 1/2
	5	2	1 3/4-12	1 1/2-12	2 1/4	2.624	7/8	1 11/16	3 5/8	1 5/16	1/2	1 3/8	2 7/8	4 13/16	3 1/16	5 5/8	6 5/8
5	1(Std.)	1	7/8-14	3/4-16	1 1/8	1.499	1/2	7/8	1 7/8	1 5/16	1/4	3/4	2 1/4	4 5/16	2 7/16	5 1/4	6 5/16
	2	3 1/2	3 1/4-12	2 1/2-12	3 1/2	4.249	1	3	5 1/8	3 3/8	5/8	1 5/8	3 1/8	5 1/16	3 5/16	6 1/8	7 3/16
	3	1 3/8	1 1/4-12	1-14	1 5/8	1.999	5/8	1 1/8	2 5/8	1 5/16	3/8	1	2 1/2	4 7/16	2 11/16	5 1/2	6 3/16
	4	1 3/4	1 1/2-12	1 1/4-12	2	2.374	3/4	1 1/2	3 1/4	1 11/16	1/2	1 1/4	2 3/4	4 11/16	2 15/16	5 3/4	6 13/16
	5	2	1 3/4-12	1 1/2-12	2 1/4	2.624	7/8	1 11/16	3 5/8	1 5/16	1/2	1 3/8	2 7/8	4 13/16	3 1/16	5 7/8	6 15/16
	6	2 1/2	2 1/4-12	1 7/8-12	3	3.124	1	2 1/16	4 5/8	2 3/8	5/8	1 5/8	3 1/8	5 1/16	3 5/16	6 1/8	7 3/16
	7	3	2 3/4-12	2 1/4-12	3 1/2	3.749	1	2 5/8	5 1/8	2 7/8	5/8	1 5/8	3 1/8	5 1/16	3 5/16	6 1/8	7 3/16
6	1(Std.)	1 3/8	1 1/4-12	1-14	1 5/8	1.999	5/8	1 1/8	2 1/2	1 5/16	1/4	7/8	2 5/8	4 15/16	2 13/16	5 7/8	7 1/16
	2	4	3 3/4-12	3-12	4	4.749	1	3 3/8	5 1/2	3 7/8	1/2	1 1/2	3 1/4	5 9/16	3 7/16	6 1/2	7 11/16
	3	1 3/4	1 1/2-12	1 1/4-12	2	2.374	3/4	1 1/2	3 1/8	1 11/16	3/8	1 1/8	2 7/8	5 3/16	3 1/16	6 1/8	7 5/16
	4	2	1 3/4-12	1 1/2-12	2 1/4	2.624	7/8	1 11/16	3 1/2	1 5/16	3/8	1 1/4	3	5 5/16	3 3/16	6 1/4	7 7/16
	5	2 1/2	2 1/4-12	1 7/8-12	3	3.124	1	2 1/16	4 1/2	2 3/8	1/2	1 1/2	3 1/4	5 9/16	3 7/16	6 1/2	7 11/16
	6	3	2 3/4-12	2 1/4-12	3 1/2	3.749	1	2 5/8	5	2 7/8	1/2	1 1/2	3 1/4	5 9/16	3 7/16	6 1/2	7 11/16
7	3 1/2	3 1/4-12	2 1/2-12	3 1/2	4.249	1	3	5	3 3/8	1/2	1 1/2	3 1/4	5 9/16	3 7/16	6 1/2	7 11/16	

* Mounting style DD not available in 1" bore.

**Dimension XI to be specified by customer.



Cap Fixed Clevis
Style BB
(NFA Style MP1)

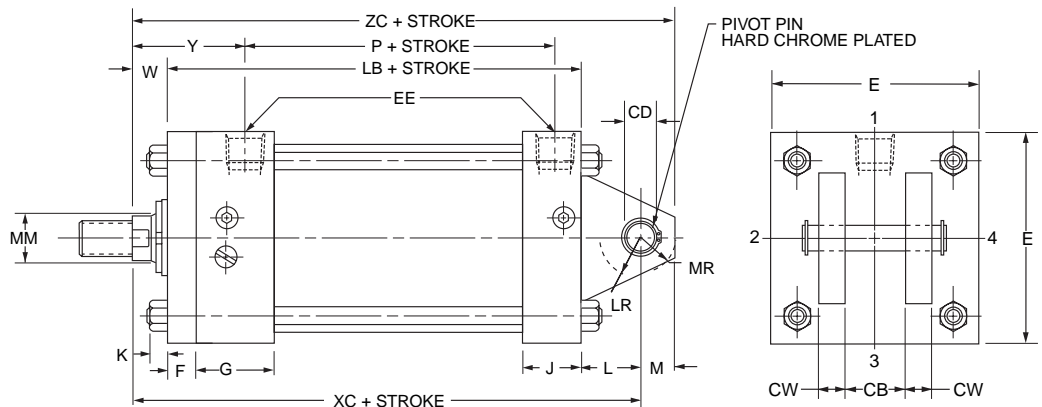
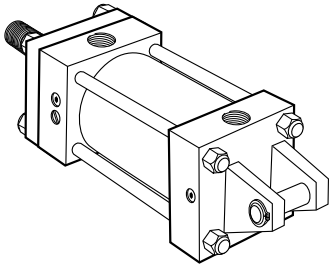

The 1", 4", 5" and 6" bore sizes have tie rod nuts at both ends as shown. Tie rods thread into cap on all other bore sizes.

1.00" Bore Series 2A – Envelope and Head Dimensions

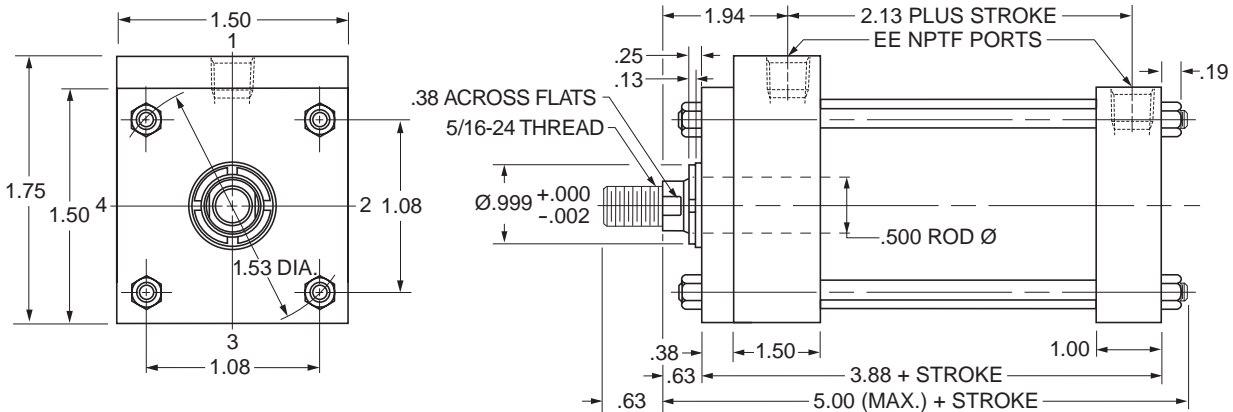

Rod End Dimensions — see table 2

Thread Style 4
(NFA Style SM)
Small Male

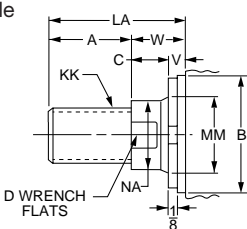

A high strength rod end stud is supplied on thread style 4 through 2" diameter rods. Larger sizes or special rod ends are cut threads. Style 4 rod ends are recommended where the workpiece is secured against the rod shoulder. When the workpiece is not shouldered, style 4 rod

Thread Style 8
(NFA Style IM)
Intermediate Male

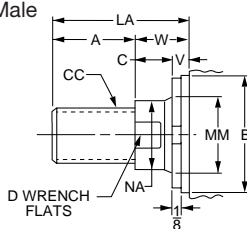

ends are recommended through 2" piston rod diameters and style 8 rod ends are recommended on larger diameters. Use style 9 for applications where female rod end threads are required. If rod end is not specified, style 4 will be supplied.

Thread Style 9
(NFA Style SF)
Small Female

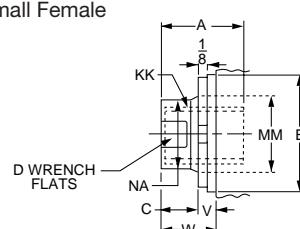

"Special" Thread Style 3

Special thread, extension, rod eye, blank, etc., are also available.

To order, specify "Style 3" and give desired dimensions for KK, A and W or WF. If otherwise special, furnish dimensioned sketch.

Table 1—Envelope and Mounting Dimensions

Bore	CB	+.000 CD• -.002	CW	E	EE NPTF	F	G	J	K	L	LR	M	MR	Add Stroke	
														LB	P
1*	†	.441†	†	■	1/4	3/8	1 1/2	1	3/16	1/2†	1/2†	7/16†	1/2†	3 7/8	2 1/8
1 1/2	3/4	.501	1/2	2	3/8**	3/8	1 1/2	1	1/4	3/4	3/4	1/2	5/8	4	2 1/4
2	3/4	.501	1/2	2 1/2	3/8**	3/8	1 1/2	1	5/16	3/4	3/4	1/2	5/8	4	2 1/4
2 1/2	3/4	.501	1/2	3	3/8**	3/8	1 1/2	1	5/16	3/4	3/4	1/2	5/8	4 1/8	2 3/8
3 1/4	1 1/4	.751	5/8	3 3/4	1/2	5/8	1 3/4	1 1/4	3/8	1 1/4	1	3/4	15/16	4 7/8	2 5/8
4	1 1/4	.751	5/8	4 1/2	1/2	5/8	1 3/4	1 1/4	3/8	1 1/4	1	3/4	15/16	4 7/8	2 5/8
5	1 1/4	.751	5/8	5 1/2	1/2	5/8	1 3/4	1 1/4	7/16	1 1/4	1	3/4	15/16	5 1/8	2 7/8
6	1 1/2	1.001	3/4	6 1/2	3/4	3/4	2	1 1/2	7/16	1 1/2	1 1/4	1	13/16	5 3/4	3 1/8

* Cushions not available on 1" bore.

** On 1", 1 1/2", 2" and 2 1/2" bore sizes, the head-end (only) pipe thread is not full depth on cylinders with No. 2 rods. Minimum of three full threads available.

† In 1" bore size model only, a single eye mounting, 7/16" thick, is used. Dimension CD (.441") is hole diameter – pin not supplied.

• Dimension CD is pin diameter except in 1" bore. ■ 1" bore head dimension is 1 3/4" x 1 1/2". See page 12.

Table 2—Rod Dimensions

Bore	Rod No.	Rod Dia. MM	Thread		Rod Extensions and Pilot Dimensions								Add Stroke		
			Style 8 CC	Style 4 & 9 KK	A	+0.000 -0.002 B	C	D	LA	NA	V	W	Y	XC	ZC
1	1(Std.)	1/2	7/16-20	5/16-24	5/8	.999	3/8	3/8	1 1/4	7/16	1/4	5/8	1 15/16	5	5 7/16
	2	5/8	1/2-20	7/16-20	3/4	1.124	3/8	1/2	1 3/8	9/16	1/4	5/8	1 15/16	5	5 7/16
1 1/2	1(Std.)	5/8	1/2-20	7/16-20	3/4	1.124	3/8	1/2	1 3/8	9/16	1/4	5/8	1 15/16	5 3/8	5 7/8
	2	1	7/8-14	3/4-16	1 1/8	1.499	1/2	7/8	2 1/8	15/16	1/2	1	2 5/16	5 3/4	6 1/4
2	1(Std.)	5/8	1/2-20	7/16-20	3/4	1.124	3/8	1/2	1 3/8	9/16	1/4	5/8	1 15/16	5 3/8	5 7/8
	2	1 3/8	1 1/4-12	1-14	1 5/8	1.999	5/8	1 1/8	2 7/8	1 5/16	5/8	1 1/4	2 9/16	6	6 1/2
	3	1	7/8-14	3/4-16	1 1/8	1.499	1/2	7/8	2 1/8	15/16	1/2	1	2 5/16	5 3/4	6 1/4
2 1/2	1(Std.)	5/8	1/2-20	7/16-20	3/4	1.124	3/8	1/2	1 3/8	9/16	1/4	5/8	1 15/16	5 1/2	6
	2	1 3/4	1 1/2-12	1 1/4-12	2	2.374	3/4	1 1/2	3 1/2	1 11/16	3/4	1 1/2	2 13/16	6 3/8	6 7/8
	3	1	7/8-14	3/4-16	1 1/8	1.499	1/2	7/8	2 1/8	15/16	1/2	1	2 5/16	5 7/8	6 3/8
	4	1 3/8	1 1/4-12	1-14	1 5/8	1.999	5/8	1 1/8	2 7/8	1 5/16	5/8	1 1/4	2 9/16	6 1/8	6 5/8
3 1/4	1(Std.)	1	7/8-14	3/4-16	1 1/8	1.499	1/2	7/8	1 7/8	15/16	1/4	3/4	2 7/16	6 7/8	7 5/8
	2	2	1 3/4-12	1 1/2-12	2 1/4	2.624	7/8	1 11/16	3 5/8	1 15/16	1/2	1 3/8	3 1/16	7 1/2	8 1/4
	3	1 3/8	1 1/4-12	1-14	1 5/8	1.999	5/8	1 1/8	2 5/8	1 5/16	3/8	1	2 11/16	7 1/8	7 7/8
	4	1 3/4	1 1/2-12	1 1/4-12	2	2.374	3/4	1 1/2	3 1/4	1 11/16	1/2	1 1/4	2 15/16	7 3/8	8 1/8
4	1(Std.)	1	7/8-14	3/4-16	1 1/8	1.499	1/2	7/8	1 7/8	15/16	1/4	3/4	2 7/16	6 7/8	7 5/8
	2	2 1/2	2 1/4-12	1 7/8-12	3	3.124	1	2 1/16	4 5/8	2 3/8	5/8	1 5/8	3 5/16	7 3/4	8 1/2
	3	1 3/8	1 1/4-12	1-14	1 5/8	1.999	5/8	1 1/8	2 5/8	1 5/16	3/8	1	2 11/16	7 1/8	7 7/8
	4	1 3/4	1 1/2-12	1 1/4-12	2	2.374	3/4	1 1/2	3 1/4	1 11/16	1/2	1 1/4	2 15/16	7 3/8	8 1/8
	5	2	1 3/4-12	1 1/2-12	2 1/4	2.624	7/8	1 11/16	3 5/8	1 15/16	1/2	1 3/8	3 1/16	7 1/2	8 1/4
5	1(Std.)	1	7/8-14	3/4-16	1 1/8	1.499	1/2	7/8	1 7/8	15/16	1/4	3/4	2 7/16	6 7/8	7 5/8
	2	3 1/2	3 1/4-12	2 1/2-12	3 1/2	4.249	1	3	5 1/8	3 3/8	5/8	1 5/8	3 5/16	8	8 3/4
	3	1 3/8	1 1/4-12	1-14	1 5/8	1.999	5/8	1 1/8	2 5/8	1 5/16	3/8	1	2 11/16	7 3/8	8 1/8
	4	1 3/4	1 1/2-12	1 1/4-12	2	2.374	3/4	1 1/2	3 1/4	1 11/16	1/2	1 1/4	2 15/16	7 5/8	8 3/8
	5	2	1 3/4-12	1 1/2-12	2 1/4	2.624	7/8	1 11/16	3 5/8	1 15/16	1/2	1 3/8	3 1/16	7 3/4	8 1/2
	6	2 1/2	2 1/4-12	1 7/8-12	3	3.124	1	2 1/16	4 5/8	2 3/8	5/8	1 5/8	3 5/16	8	8 3/4
	7	3	2 3/4-12	2 1/4-12	3 1/2	3.749	1	2 5/8	5 1/8	2 7/8	5/8	1 5/8	3 5/16	8	8 3/4
6	1(Std.)	1 3/8	1 1/4-12	1-14	1 5/8	1.999	5/8	1 1/8	2 1/2	1 5/16	1/4	7/8	2 13/16	8 1/8	9 1/8
	2	4	3 3/4-12	3-12	4	4.749	1	3 3/8	5 1/2	3 7/8	1/2	1 1/2	3 7/16	8 3/4	9 3/4
	3	1 3/4	1 1/2-12	1 1/4-12	2	2.374	3/4	1 1/2	3 1/8	1 11/16	3/8	1 1/8	3 1/16	8 3/8	9 3/8
	4	2	1 3/4-12	1 1/2-12	2 1/4	2.624	7/8	1 11/16	3 1/2	1 15/16	3/8	1 1/4	3 3/16	8 1/2	9 1/2
	5	2 1/2	2 1/4-12	1 7/8-12	3	3.124	1	2 1/16	4 1/2	2 3/8	1/2	1 1/2	3 7/16	8 3/4	9 3/4
	6	3	2 3/4-12	2 1/4-12	3 1/2	3.749	1	2 5/8	5	2 7/8	1/2	1 1/2	3 7/16	8 3/4	9 3/4
7	3 1/2	3 1/4-12	2 1/2-12	3 1/2	4.249	1	3	5	3 3/8	1/2	1 1/2	3 7/16	8 3/4	9 3/4	

Table 3 — Envelope and Mounting Dimensions



Tie Rods Extended
Style TB
(NFFPA Style MX3)

Style TB (NFFPA MX3)
Head Tie Rods Extended, illustrated: Style TC (NFFPA MX2), Cap Tie Rods Extended; and Style TD (NFFPA MX1), Both Ends Tie Rods Extended are also available. All "T" styles can be dimensioned from Style TB drawing at right.

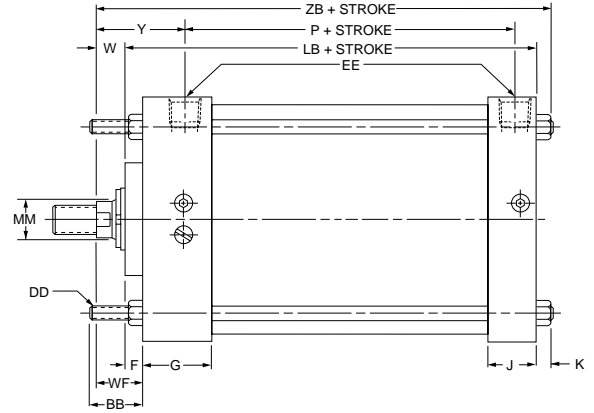
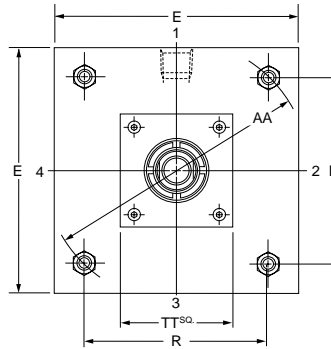
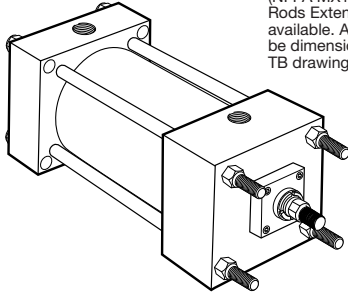

Head Square Flange
Style JB
(NFFPA Style ME3)

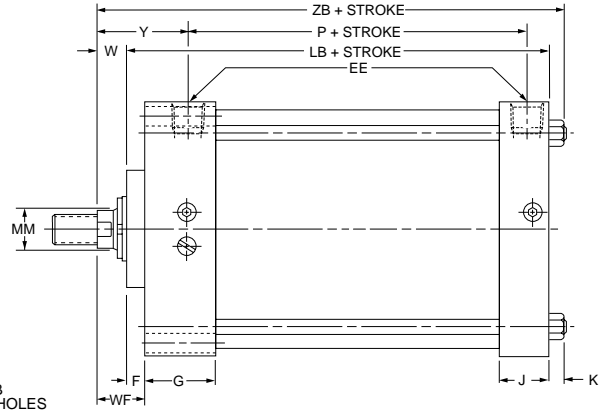
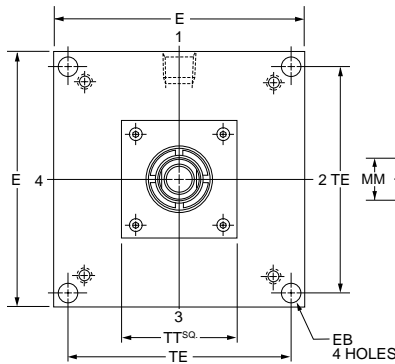
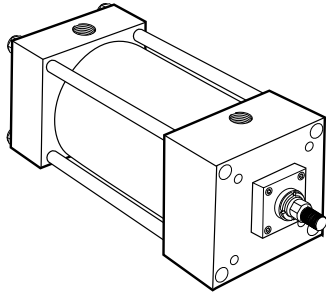

Cap Square Flange
Style HB
(NFFPA Style ME4)

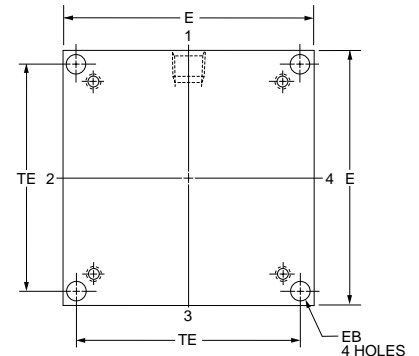
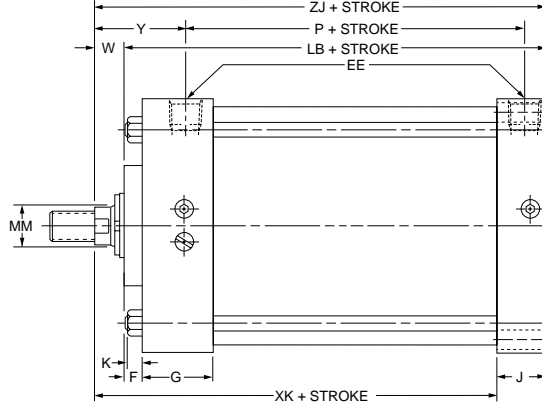
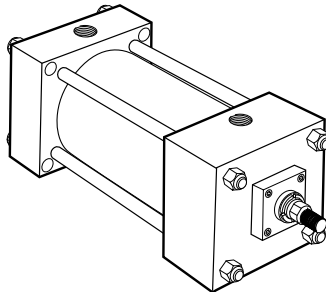

Rod End Dimensions — see table 2

Thread Style 4
(NFFPA Style SM)
Small Male

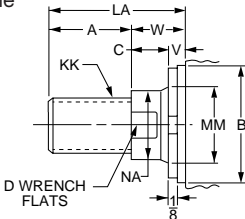

A high strength rod end stud is supplied on thread style 4 through 2" diameter rods. Larger sizes or special rod ends are cut threads. Style 4 rod ends are recommended where the workpiece is secured against the rod shoulder. When the workpiece is not shouldered, style 4 rod

Thread Style 8
(NFFPA Style IM)
Intermediate Male

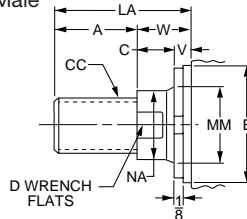

ends are recommended through 2" piston rod diameters and style 8 rod ends are recommended on larger diameters. Use style 9 for applications where female rod end threads are required. If rod end is not specified, style 4 will be supplied.

Thread Style 9
(NFFPA Style SF)
Small Female

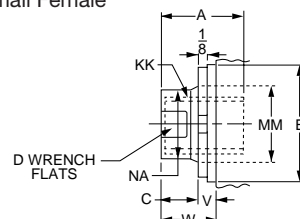

"Special" Thread Style 3

Special thread, extension, rod eye, blank, etc., are also available.

To order, specify "Style 3" and give desired dimensions for KK, A and W or WF. If otherwise special, furnish dimensioned sketch.

Side Lug
Style C
(NFFA Style MS2)

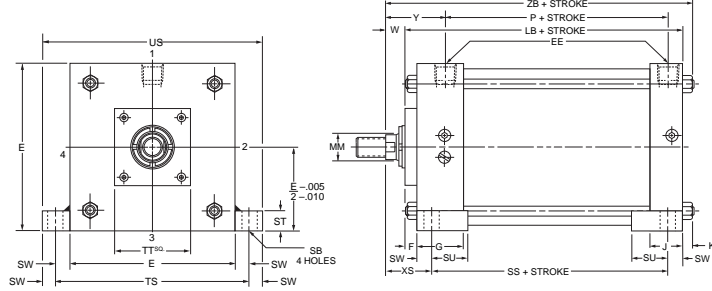

Side Tapped
Style F
(NFFA Style MS4)

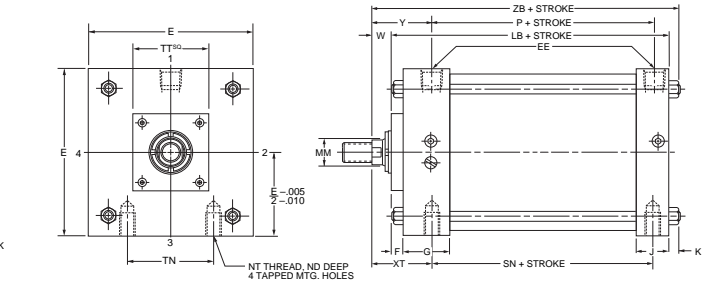

Cap Trunnion
Style DB
(NFFA Style MT2)

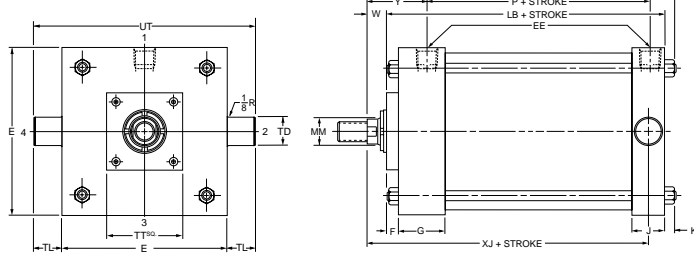

Head Trunnion
Style D
(NFFA Style MT1)

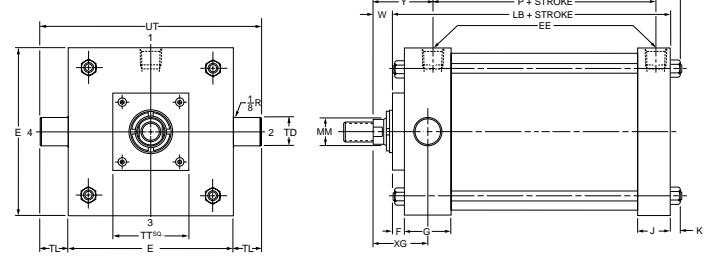

Cap Fixed Clevis
Style BB
(NFFA Style MP1)

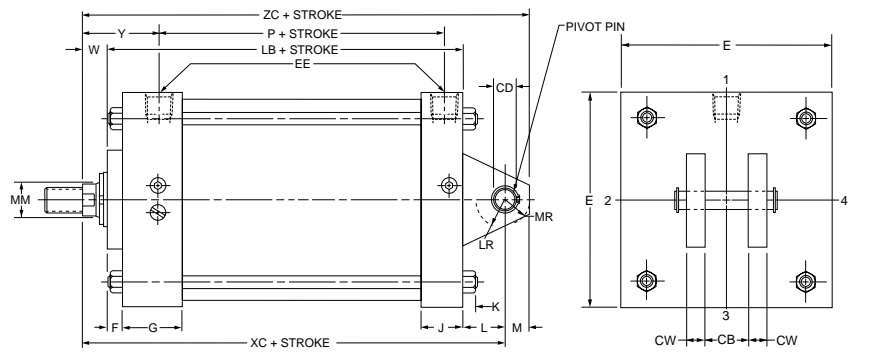
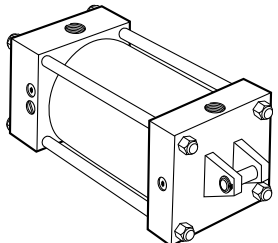

Note: Other mounting styles and double rod end cylinders are available on request. Consult factory for details.

Table 1—Envelope and Mounting Dimensions

Bore	AA	BB	CB	CD +0.000 -0.002	CW	DD	E	EB	EE	F	G	J	K	L	LR	M	MR	ND	NT	R	SB	ST	SU	SW	TD +0.000 -0.001	TE	TL	TN	TS	US	UT	Add Stroke			
																																LB	P	SN	SS
7	8.1	2 ⁵ / ₁₆	1 ¹ / ₂	1.001	3/4	5/8-18	7 ¹ / ₂	9 ¹ / ₁₆	3/4	3/4	2	1 ¹ / ₂	9 ¹ / ₁₆	1 ¹ / ₂	1 ¹ / ₄	1	1 ¹ / ₁₆	1 ¹ / ₈	3/4-10	5.73	1 ¹³ / ₁₆	1	1 ⁹ / ₁₆	1 ¹¹ / ₁₆	1.375	6 ³ / ₄	1 ¹ / ₈	3 ¹ / ₂	8 ⁷ / ₈	10 ¹ / ₄	10 ¹ / ₄	5 ⁷ / ₈	3 ¹ / ₄	3 ¹ / ₄	3 ³ / ₄

Table 2—Rod Dimensions

Bore	Rod No.	Rod Dia. MM	Thread		Rod Extensions and Pilot Dimensions																			
			Style 8 CC	Style 4 & 9 KK	A	+0.000 -0.002 B	C	D	LA	NA	V	W	WF	Y	TT	XG	XS	XT	XC	XJ	XK	ZB	ZC	ZJ
7	1	1 ³ / ₈	1 ¹ / ₄ -12	1-14	1 ⁵ / ₈	1.999	5/8	1 ¹ / ₈	2 ¹ / ₂	1 ⁵ / ₁₆	1/4	7/8	1 ⁵ / ₈	2 ¹³ / ₁₆	4	2 ⁵ / ₈	2 ⁵ / ₁₆	2 ¹³ / ₁₆	8 ¹ / ₄	6	5 ¹ / ₄	7 ⁵ / ₁₆	9 ¹ / ₄	6 ³ / ₄
	3	1 ³ / ₄	1 ¹ / ₂ -12	1 ¹ / ₄ -12	2	2.374	3/4	1 ¹ / ₂	3 ¹ / ₈	1 ¹¹ / ₁₆	3/8	1 ¹ / ₈	1 ⁷ / ₈	3 ¹ / ₁₆	4	2 ⁷ / ₈	2 ⁹ / ₁₆	3 ¹ / ₁₆	8 ¹ / ₂	6 ¹ / ₄	5 ¹ / ₂	7 ⁹ / ₁₆	9 ¹ / ₂	7
	4	2	1 ³ / ₄ -12	1 ¹ / ₂ -12	2 ¹ / ₄	2.624	7/8	1 ¹¹ / ₁₆	3 ¹ / ₂	1 ¹⁵ / ₁₆	3/8	1 ¹ / ₄	2	3 ³ / ₁₆	4	3	2 ¹¹ / ₁₆	3 ³ / ₁₆	8 ⁵ / ₈	6 ³ / ₈	5 ⁵ / ₈	7 ¹¹ / ₁₆	9 ⁵ / ₈	7 ¹ / ₈

Table 3 — Envelope and Mounting Dimensions

Bore	Rod No.	Rod Dia. MM	Rod Extensions and Pilot Dimensions													Add Stroke				
			TT	XG	XS	XT	XC	XJ	XK	ZB	ZC	ZJ	LB	P	SN	SS				
																	4	2 ⁵ / ₈	2 ⁵ / ₁₆	2 ¹³ / ₁₆
7	1	1 ³ / ₈	4	2 ⁵ / ₈	2 ⁵ / ₁₆	2 ¹³ / ₁₆	8 ¹ / ₄	6	5 ¹ / ₄	7 ⁵ / ₁₆	9 ¹ / ₄	6 ³ / ₄	5 ⁷ / ₈	3 ¹ / ₄	3 ¹ / ₄	3 ³ / ₄				
	3	1 ³ / ₄	4	2 ⁷ / ₈	2 ⁹ / ₁₆	3 ¹ / ₁₆	8 ¹ / ₂	6 ¹ / ₄	5 ¹ / ₂	7 ⁹ / ₁₆	9 ¹ / ₂	7	5 ⁷ / ₈	3 ¹ / ₄	3 ¹ / ₄	3 ³ / ₄				
	4	4	3	2 ¹¹ / ₁₆	3 ³ / ₁₆	8 ⁵ / ₈	6 ³ / ₈	5 ⁵ / ₈	7 ¹¹ / ₁₆	9 ⁵ / ₈	7 ¹ / ₈	7	5 ⁷ / ₈	3 ¹ / ₄	3 ¹ / ₄	3 ³ / ₄				



Tie Rods Extended
Style TB
(NFFPA Style MX3)

Style TB (NFFPA MX3)
Head Tie Rods Extended,
illustrated: Style TC (NFFPA
MX2), Cap Tie Rods
Extended; and Style TD
(NFFPA MX1), Both Ends Tie
Rods Extended are also
available. All "T" styles can
be dimensioned from Style
TB drawing at right.

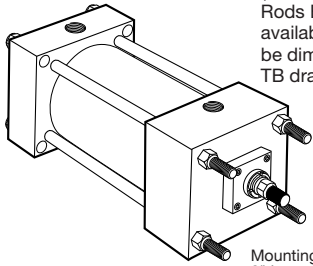

Mounting styles TB & TD not offered in
8" bore, rod codes #2, 9 and 0.

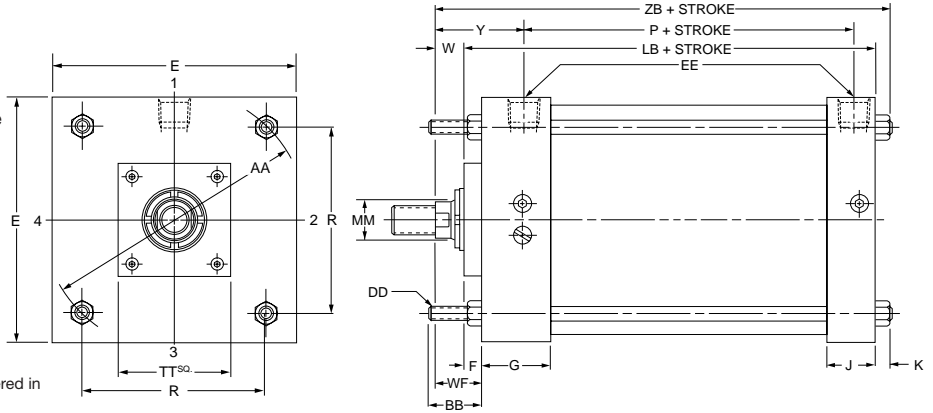

Head Square Flange
Style JB
(NFFPA Style ME3)

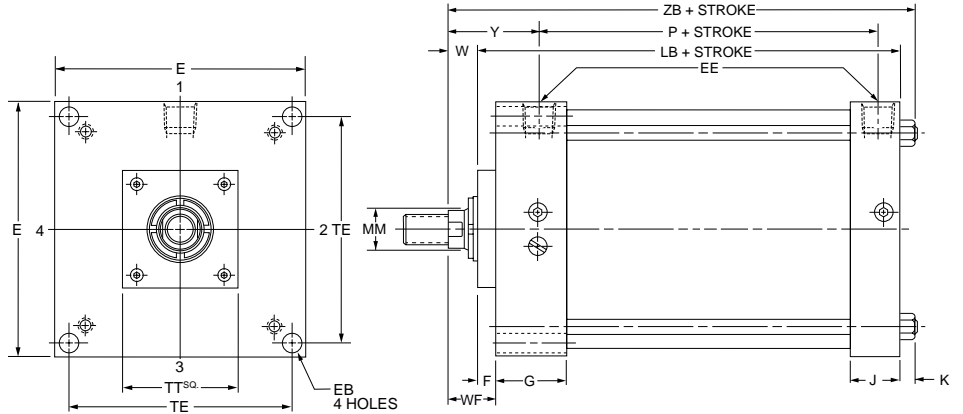
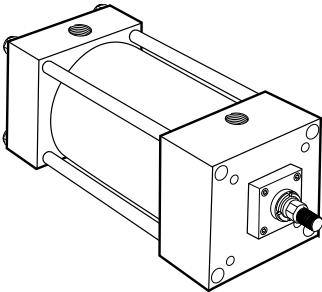

Cap Square Flange
Style HB
(NFFPA Style ME4)

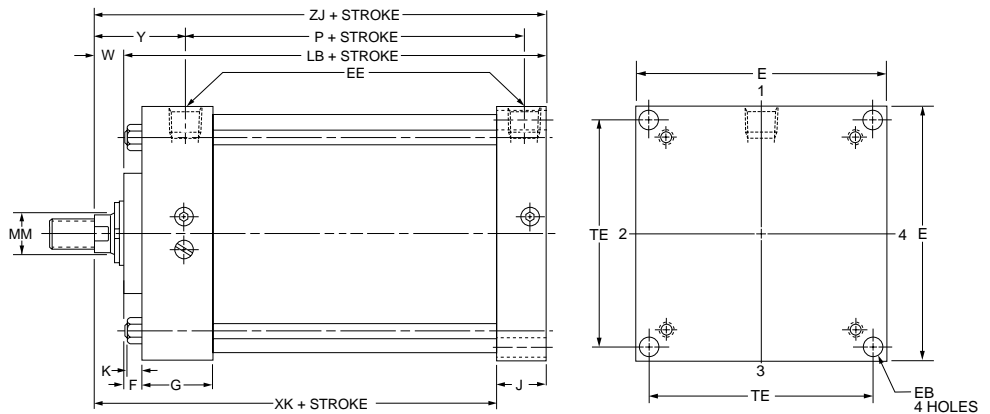
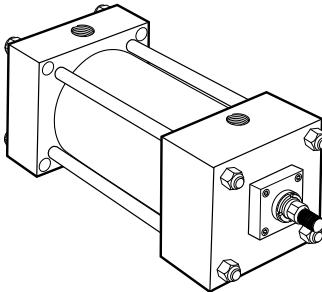

Rod End Dimensions — see table 2

Thread Style 4
(NFFPA Style SM)
Small Male

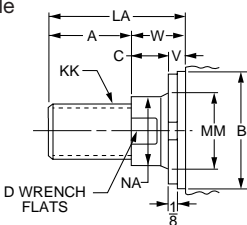

A high strength rod end stud is supplied on thread style 4 through 2" diameter rods. Larger sizes or special rod ends are cut threads. Style 4 rod ends are recommended where the workpiece is secured against the rod shoulder. When the workpiece is not shouldered, style 4 rod

Thread Style 8
(NFFPA Style IM)
Intermediate Male

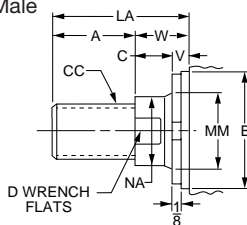

ends are recommended through 2" piston rod diameters and style 8 rod ends are recommended on larger diameters. Use style 9 for applications where female rod end threads are required. If rod end is not specified, style 4 will be supplied.

Thread Style 9
(NFFPA Style SF)
Small Female

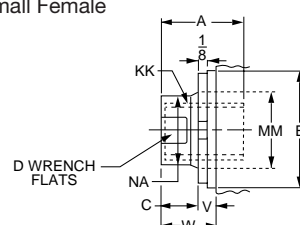

"Special" Thread Style 3

Special thread, extension, rod eye, blank, etc., are also available.

To order, specify "Style 3" and give desired dimensions for KK, A and W or WF. If otherwise special, furnish dimensioned sketch.

Side Lug
Style C
(NFPA Style MS2)

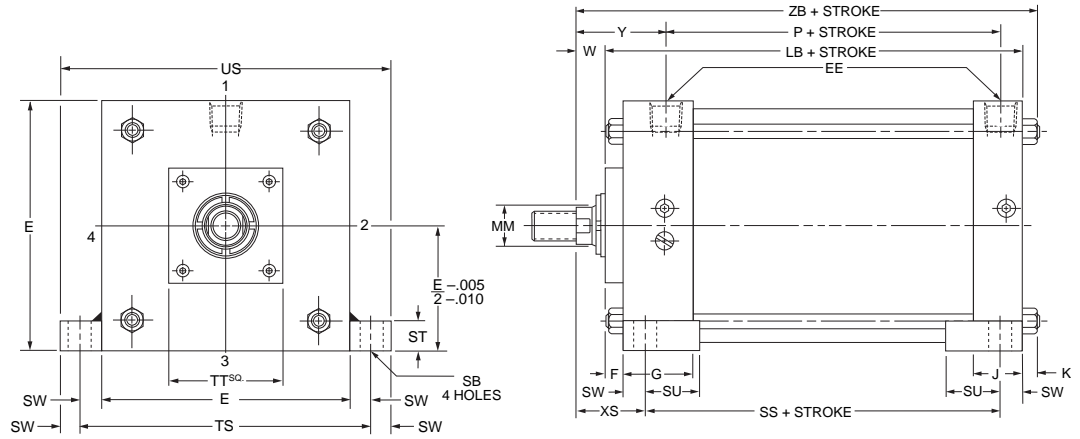
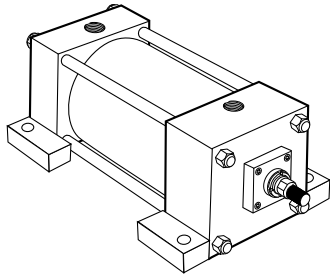

Rod End Dimensions — see table 2

Thread Style 4
 (NFPA Style SM)
 Small Male

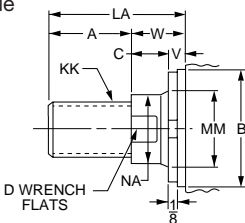

A high strength rod end stud is supplied on thread style 4 through 2" diameter rods. Larger sizes or special rod ends are cut threads. Style 4 rod ends are recommended where the workpiece is secured against the rod shoulder. When the workpiece is not shouldered, style 4 rod

Thread Style 8
 (NFPA Style IM)
 Intermediate Male

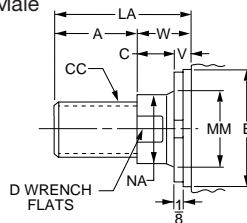

ends are recommended through 2" piston rod diameters and style 8 rod ends are recommended on larger diameters. Use style 9 for applications where female rod end threads are required. If rod end is not specified, style 4 will be supplied.

Thread Style 9
 (NFPA Style SF)
 Small Female

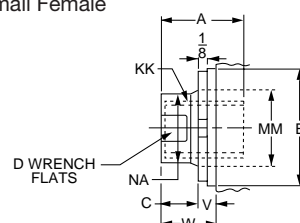

"Special" Thread Style 3

Special thread, extension, rod eye, blank, etc., are also available.

To order, specify "Style 3" and give desired dimensions for KK, A and W or WF. If otherwise special, furnish dimensioned sketch.

Side Tapped
Style F
(NFFPA Style MS4)

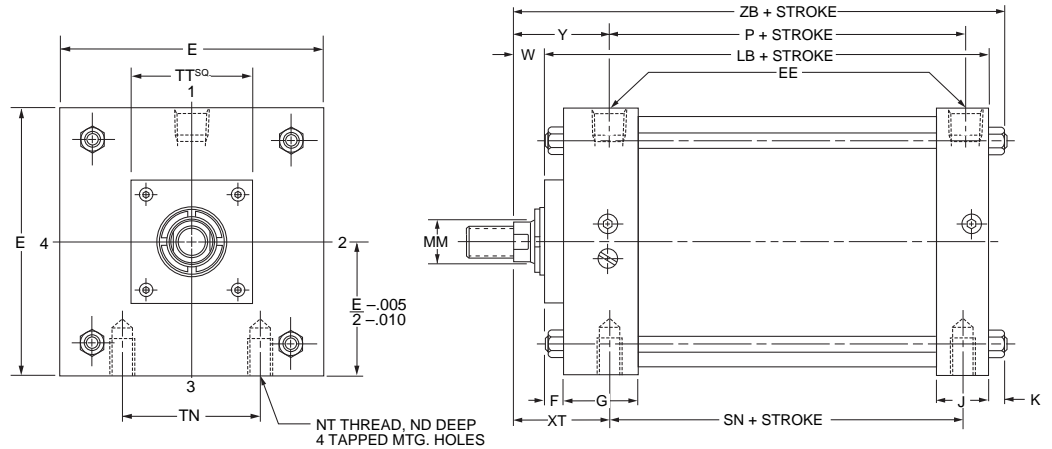
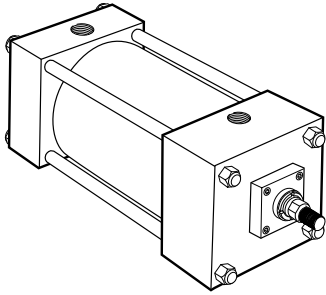

Rod End Dimensions — see table 2

Thread Style 4
 (NFFPA Style SM)
 Small Male

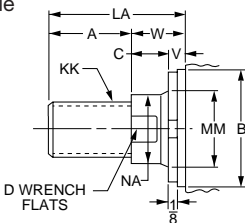

A high strength rod end stud is supplied on thread style 4 through 2" diameter rods. Larger sizes or special rod ends are cut threads. Style 4 rod ends are recommended where the workpiece is secured against the rod shoulder. When the workpiece is not shouldered, style 4 rod

Thread Style 8
 (NFFPA Style IM)
 Intermediate Male

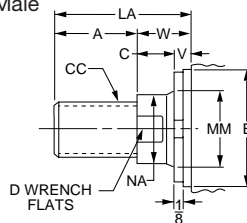

ends are recommended through 2" piston rod diameters and style 8 rod ends are recommended on larger diameters. Use style 9 for applications where female rod end threads are required. If rod end is not specified, style 4 will be supplied.

Thread Style 9
 (NFFPA Style SF)
 Small Female

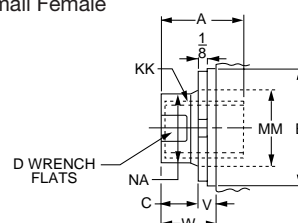

"Special" Thread Style 3

Special thread, extension, rod eye, blank, etc., are also available.

To order, specify "Style 3" and give desired dimensions for KK, A and W or WF. If otherwise special, furnish dimensioned sketch.

Cap Fixed Clevis
 Style BB
 (NFFPA Style MP1)

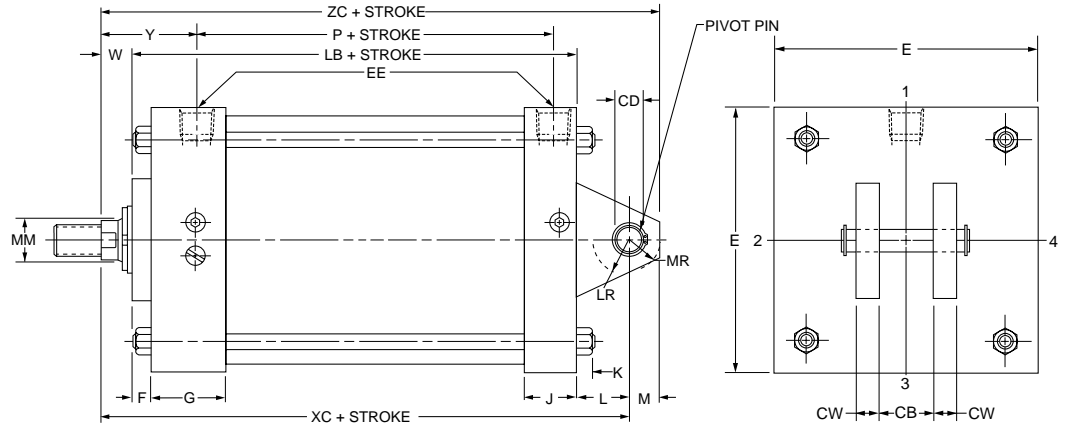
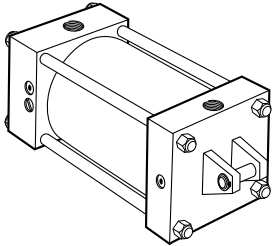

Rod End Dimensions — see table 2

Thread Style 4
 (NFFPA Style SM)
 Small Male

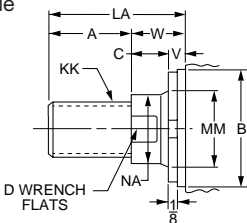

A high strength rod end stud is supplied on thread style 4 through 2" diameter rods. Larger sizes or special rod ends are cut threads. Style 4 rod ends are recommended where the workpiece is secured against the rod shoulder. When the workpiece is not shouldered, style 4 rod

Thread Style 8
 (NFFPA Style IM)
 Intermediate Male

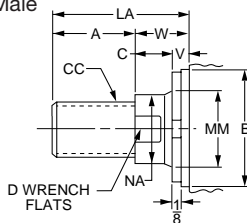

ends are recommended through 2" piston rod diameters and style 8 rod ends are recommended on larger diameters. Use style 9 for applications where female rod end threads are required. If rod end is not specified, style 4 will be supplied.

Thread Style 9
 (NFFPA Style SF)
 Small Female

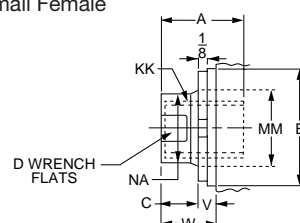

"Special" Thread Style 3

Special thread, extension, rod eye, blank, etc., are also available.

To order, specify "Style 3" and give desired dimensions for KK, A and W or WF. If otherwise special, furnish dimensioned sketch.

Table 1—Envelope and Mounting Dimensions

Bore	CB	+.000 CD* -.002	CW	E	EE NPTF	F	G	J	K	L	LR	M	MR	Add Stroke	
														LB	P
8	1 1/2	1.001	3/4	8 1/2	3/4	3/4	2	1 1/2	9/16	1 1/2	1 1/4	1	1 3/16	5 7/8	3 1/4
10	2	1.376	1	10 5/8	1	3/4	2 1/4	2	11/16	2 1/8	1 7/8	1 3/8	1 5/8	7 1/8	4 1/8
12	2 1/2	1.751	1 1/4	12 3/4	1	3/4	2 1/4	2	11/16	2 1/4	2 1/8	1 3/4	2 1/8	7 5/8	4 5/8
14	2 1/2	2.001	1 1/4	14 3/4	1 1/4	3/4	2 3/4	2 1/4	3/4	2 1/2	2 3/8	2	2 3/8	8 7/8	5 1/2

* CD is pin diameter.

Table 2—Rod Dimensions

Bore	Rod No.	Rod Dia. MM	Thread		Rod Extensions and Pilot Dimensions								Add Stroke		
			Style 8 CC	Style 4 & 9 KK	A	+.000 -.002 B	C	D	LA	NA	V	W	Y	XC	ZC
8	1(Std.)	1 3/8	1 1/4-12	1-14	1 5/8	1.999	5/8	1 1/8	2 1/2	1 5/16	1/4	7/8	2 13/16	8 1/4	9 1/4
	2	5 1/2	5 1/4-12	4-12	5 1/2	6.249	1	4 5/8	7	5 3/8	1/2	1 1/2	3 7/16	8 7/8	9 7/8
	3	1 3/4	1 1/2-12	1 1/4-12	2	2.374	3/4	1 1/2	3 1/8	1 11/16	3/8	1 1/8	3 1/16	8 1/2	9 1/2
	4	2	1 3/4-12	1 1/2-12	2 1/4	2.624	7/8	1 11/16	3 1/2	1 5/16	3/8	1 1/4	3 3/16	8 5/8	9 5/8
	5	2 1/2	2 1/4-12	1 7/8-12	3	3.124	1	2 1/16	4 1/2	2 3/8	1/2	1 1/2	3 7/16	8 7/8	9 7/8
	6	3	2 3/4-12	2 1/4-12	3 1/2	3.749	1	2 5/8	5	2 7/8	1/2	1 1/2	3 7/16	8 7/8	9 7/8
	7	3 1/2	3 1/4-12	2 1/2-12	3 1/2	4.249	1	3	5	3 3/8	1/2	1 1/2	3 7/16	8 7/8	9 7/8
	8	4	3 3/4-12	3-12	4	4.749	1	3 3/8	5 1/2	3 7/8	1/2	1 1/2	3 7/16	8 7/8	9 7/8
	9	4 1/2	4 1/4-12	3 1/4-12	4 1/2	5.249	1	3 7/8	6	4 3/8	1/2	1 1/2	3 7/16	8 7/8	9 7/8
10	1(Std.)	1 3/4	1 1/2-12	1 1/4-12	2	2.374	3/4	1 1/2	3 1/8	1 11/16	3/8	1 1/8	3 1/8	10 3/8	11 3/4
	3	2	1 3/4-12	1 1/2-12	2 1/4	2.624	7/8	1 11/16	3 1/2	1 5/16	3/8	1 1/4	3 1/4	10 1/2	11 7/8
	4	2 1/2	2 1/4-12	1 7/8-12	3	3.124	1	2 1/16	4 1/2	2 3/8	1/2	1 1/2	3 1/2	10 3/4	12 1/8
	5	3	2 3/4-12	2 1/4-12	3 1/2	3.749	1	2 5/8	5	2 7/8	1/2	1 1/2	3 1/2	10 3/4	12 1/8
	6	3 1/2	3 1/4-12	2 1/2-12	3 1/2	4.249	1	3	5	3 3/8	1/2	1 1/2	3 1/2	10 3/4	12 1/8
	7	4	3 3/4-12	3-12	4	4.749	1	3 3/8	5 1/2	3 7/8	1/2	1 1/2	3 1/2	10 3/4	12 1/8
	8	4 1/2	4 1/4-12	3 1/4-12	4 1/2	5.249	1	3 7/8	6	4 3/8	1/2	1 1/2	3 1/2	10 3/4	12 1/8
	9	5	4 3/4-12	3 1/2-12	5	5.749	1	4 1/4	6 1/2	4 7/8	1/2	1 1/2	3 1/2	10 3/4	12 1/8
	0	5 1/2	5 1/4-12	4-12	5 1/2	6.249	1	4 5/8	7	5 3/8	1/2	1 1/2	3 1/2	10 3/4	12 1/8
12	1(Std.)	2	1 3/4-12	1 1/2-12	2 1/4	2.624	7/8	1 11/16	3 1/2	1 5/16	3/8	1 1/4	3 1/4	11 1/8	12 7/8
	3	2 1/2	2 1/4-12	1 7/8-12	3	3.124	1	2 1/16	4 1/2	2 3/8	1/2	1 1/2	3 1/2	11 3/8	13 1/8
	4	3	2 3/4-12	2 1/4-12	3 1/2	3.749	1	2 5/8	5	2 7/8	1/2	1 1/2	3 1/2	11 3/8	13 1/8
	5	3 1/2	3 1/4-12	2 1/2-12	3 1/2	4.249	1	3	5	3 3/8	1/2	1 1/2	3 1/2	11 3/8	13 1/8
	6	4	3 3/4-12	3-12	4	4.749	1	3 3/8	5 1/2	3 7/8	1/2	1 1/2	3 1/2	11 3/8	13 1/8
	7	4 1/2	4 1/4-12	3 1/4-12	4 1/2	5.249	1	3 7/8	6	4 3/8	1/2	1 1/2	3 1/2	11 3/8	13 1/8
	8	5	4 3/4-12	3 1/2-12	5	5.749	1	4 1/4	6 1/2	4 7/8	1/2	1 1/2	3 1/2	11 3/8	13 1/8
	9	5 1/2	5 1/4-12	4-12	5 1/2	6.249	1	4 5/8	7	5 3/8	1/2	1 1/2	3 1/2	11 3/8	13 1/8
	0	6	5 1/4-12	4 1/2-12	6	6.749	1	5	8	6 3/8	1/2	1 1/2	3 1/2	11 3/8	13 1/8
14	1(Std.)	2 1/2	2 1/4-12	1 7/8-12	3	3.124	1	2 1/16	4 1/2	2 3/8	1/2	1 1/2	3 3/16	12 7/8	14 7/8
	3	3	2 3/4-12	2 1/4-12	3 1/2	3.749	1	2 5/8	5	2 7/8	1/2	1 1/2	3 3/16	12 7/8	14 7/8
	4	3 1/2	3 1/4-12	2 1/2-12	3 1/2	4.249	1	3	5	3 3/8	1/2	1 1/2	3 3/16	12 7/8	14 7/8
	5	4	3 3/4-12	3-12	4	4.749	1	3 3/8	5 1/2	3 7/8	1/2	1 1/2	3 3/16	12 7/8	14 7/8
	6	4 1/2	4 1/4-12	3 1/4-12	4 1/2	5.249	1	3 7/8	6	4 3/8	1/2	1 1/2	3 3/16	12 7/8	14 7/8
	7	5	4 3/4-12	3 1/2-12	5	5.749	1	4 1/4	6 1/2	4 7/8	1/2	1 1/2	3 3/16	12 7/8	14 7/8
8	5 1/2	5 1/4-12	4-12	5 1/2	6.249	1	4 5/8	7	5 3/8	1/2	1 1/2	3 3/16	12 7/8	14 7/8	

Table 3 — Envelope and Mounting Dimensions

Head Trunnion
Style D
(NFFPA Style MT1)

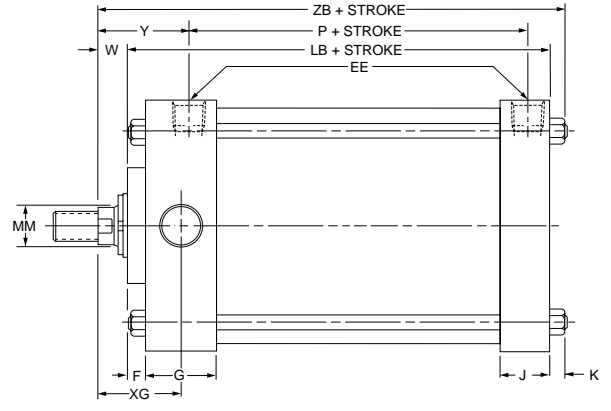
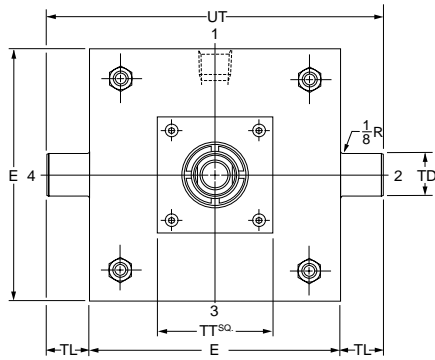
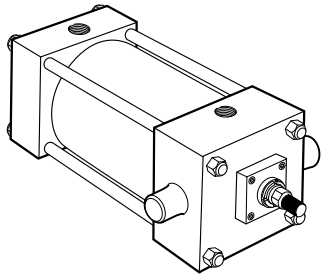

Cap Trunnion
Style DB
(NFFPA Style MT2)

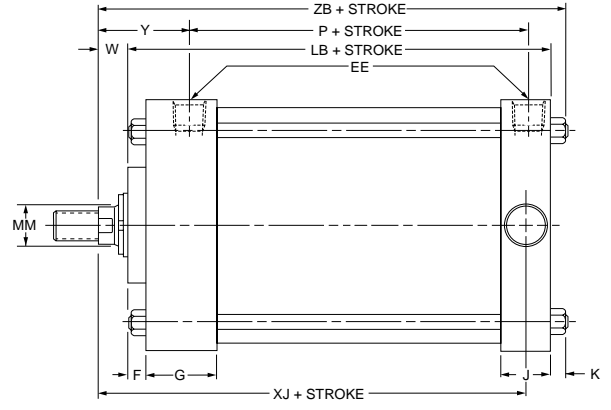
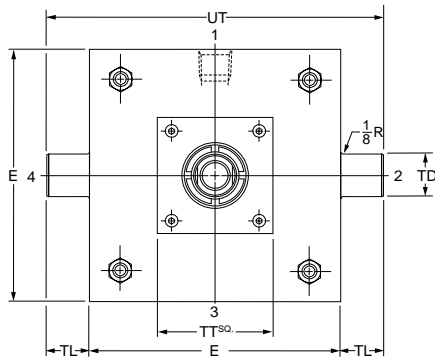
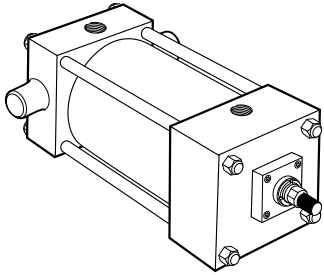

Intermediate Fixed Trunnion
Style DD
(NFFPA Style MT4)

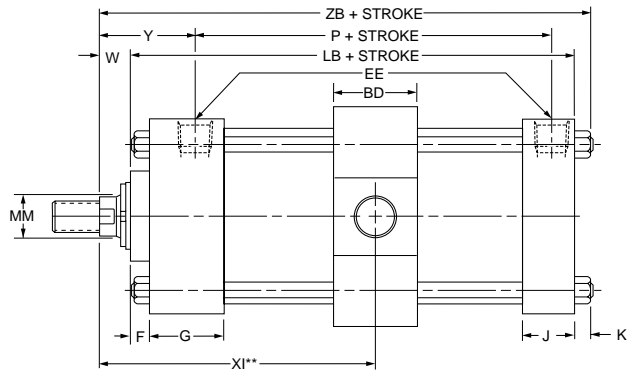
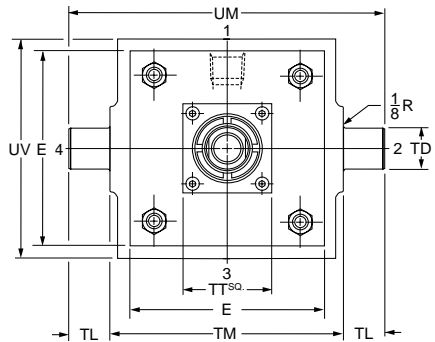
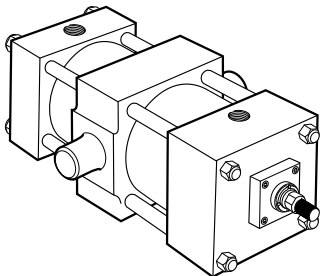

Rod End Dimensions — see table 2

Thread Style 4
(NFFPA Style SM)
Small Male

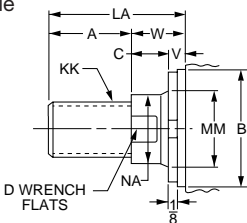

A high strength rod end stud is supplied on thread style 4 through 2" diameter rods. Larger sizes or special rod ends are cut threads. Style 4 rod ends are recommended where the workpiece is secured against the rod shoulder. When the workpiece is not shouldered, style 4 rod

Thread Style 8
(NFFPA Style IM)
Intermediate Male

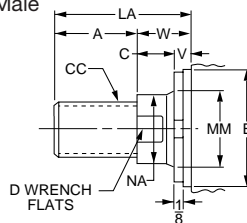

ends are recommended through 2" piston rod diameters and style 8 rod ends are recommended on larger diameters. Use style 9 for applications where female rod end threads are required. If rod end is not specified, style 4 will be supplied.

Thread Style 9
(NFFPA Style SF)
Small Female

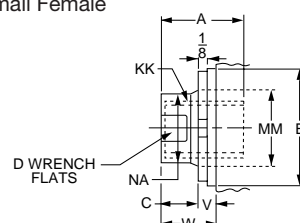

"Special" Thread Style 3

Special thread, extension, rod eye, blank, etc., are also available.

To order, specify "Style 3" and give desired dimensions for KK, A and W or WF. If otherwise special, furnish dimensioned sketch.

Table 1—Envelope and Mounting Dimensions

Bore	BD	E	EE NPTF	F	G	J	K	+.000 TD -.001 B	TL	TM	UM	UT	UV	Add Stroke		Style DD Min. Stroke
														LB	P	
8	2 1/2	8 1/2	3/4	3/4	2	1 1/2	9/16	1.375	1 3/8	9 3/4	12 1/2	11 1/4	9 1/2	5 7/8	3 1/4	7/8
10	3	10 5/8	1	3/4	2 1/4	2	1 1/16	1.750	1 3/4	12	15 1/2	14 1/8	11 3/4	7 1/8	4 1/8	7/8
12	3	12 3/4	1	3/4	2 1/4	2	1 1/16	1.750	1 3/4	14	17 1/2	16 1/4	13 3/4	7 5/8	4 5/8	3/8
14	3 1/2	14 3/4	1 1/4	3/4	2 3/4	2 1/4	3/4	2.000	2	16 1/4	20 1/4	18 3/4	16	8 7/8	5 1/2	3/8

Table 2—Rod Dimensions

Bore	Rod No.	Rod Dia. MM	Thread		Rod Extensions and Pilot Dimensions								Add Stroke					
			Style 8 CC	Style 4 & 9 KK	A	+.000 -.002 B	C	D	LA	NA	V	W	TT	XG	Min.** XI	Y	XJ	ZB
8	1(Std.)	1 3/8	1 1/4-12	1-14	1 5/8	1.999	5/8	1 1/8	2 1/2	1 5/16	1/4	7/8	4	2 5/8	4 15/16	2 13/16	6	7 5/16
	2	5 1/2	5 1/4-12	4-12	5 1/2	6.249	1	4 5/8	7	5 3/8	1/2	1 1/2	7	3 1/4	5 9/16	3 7/16	6 5/8	7 15/16
	3	1 3/4	1 1/2-12	1 1/4-12	2	2.374	3/8	1 1/2	3 1/8	1 11/16	3/8	1 1/8	4	2 7/8	5 3/16	3 1/16	6 1/4	7 9/16
	4	2	1 3/4-12	1 1/2-12	2 1/4	2.624	7/8	1 11/16	3 1/2	1 15/16	3/8	1 1/4	4	3	5 5/16	3 3/16	6 3/8	7 11/16
	5	2 1/2	2 1/4-12	1 7/8-12	3	3.124	1	2 1/16	4 1/2	2 3/8	1/2	1 1/2	4	3 1/4	5 9/16	3 7/16	6 5/8	7 15/16
	6	3	2 3/4-12	2 1/4-12	3 1/2	3.749	1	2 5/8	5	2 7/8	1/2	1 1/2	5 1/2	3 1/4	5 3/16	3 7/16	6 5/8	7 15/16
	7	3 1/2	3 3/4-12	2 1/2-12	3 1/2	4.249	1	3	5	3 3/8	1/2	1 1/2	5 1/2	3 1/4	5 9/16	3 7/16	6 5/8	7 15/16
	8	4	3 3/4-12	3-12	4	4.749	1	3 3/8	5 1/2	3 7/8	1/2	1 1/2	5 1/2	3 1/4	5 9/16	3 7/16	6 5/8	7 15/16
	9	4 1/2	4 1/4-12	3 1/4-12	4 1/2	5.249	1	3 7/8	6	4 3/8	1/2	1 1/2	7	3 1/4	5 9/16	3 7/16	6 5/8	7 15/16
10	1(Std.)	1 3/4	1 1/2-12	1 1/4-12	2	2.374	3/4	1 1/2	3 1/8	1 11/16	3/8	1 1/8	4	3	5 11/16	3 1/8	7 1/4	8 15/16
	3	2	1 3/4-12	1 1/2-12	2 1/4	2.624	7/8	1 11/16	3 1/2	1 15/16	3/8	1 1/4	4	3 1/8	5 13/16	3 1/4	7 3/8	9 1/16
	4	2 1/2	2 1/4-12	1 7/8-12	3	3.124	1	2 1/16	4 1/2	2 3/8	1/2	1 1/2	4	3 3/8	6 1/16	3 1/2	7 5/8	9 5/16
	5	3	2 3/4-12	2 1/4-12	3 1/2	3.749	1	2 5/8	5	2 7/8	1/2	1 1/2	5 1/2	3 3/8	6 1/16	3 1/2	7 5/8	9 5/16
	6	3 1/2	3 3/4-12	2 1/2-12	3 1/2	4.249	1	3	5	3 3/8	1/2	1 1/2	5 1/2	3 3/8	6 1/16	3 1/2	7 5/8	9 5/16
	7	4	3 3/4-12	3-12	4	4.749	1	3 3/8	5 1/2	3 7/8	1/2	1 1/2	5 1/2	3 3/8	6 1/16	3 1/2	7 5/8	9 5/16
	8	4 1/2	4 1/4-12	3 1/4-12	4 1/2	5.249	1	3 7/8	6	4 3/8	1/2	1 1/2	7	3 3/8	6 1/16	3 1/2	7 5/8	9 5/16
	9	5	4 3/4-12	3 1/2-12	5	5.749	1	4 1/4	6 1/2	4 7/8	1/2	1 1/2	7	3 3/8	6 1/16	3 1/2	7 5/8	9 5/16
	0	5 1/2	5 1/4-12	4-12	5 1/2	6.249	1	4 5/8	7	5 3/8	1/2	1 1/2	7	3 3/8	6 1/16	3 1/2	7 5/8	9 5/16
12	1(Std.)	2	1 3/4-12	1 1/2-12	2 1/4	2.624	7/8	1 11/16	3 1/2	1 15/16	3/8	1 1/4	4	3 1/8	5 13/16	3 1/4	7 7/8	9 9/16
	3	2 1/2	2 1/4-12	1 7/8-12	3	3.124	1	2 1/16	4 1/2	2 3/8	1/2	1 1/2	4	3 3/8	6 1/16	3 1/2	8 1/8	9 13/16
	4	3	2 3/4-12	2 1/4-12	3 1/2	3.749	1	2 5/8	5	2 7/8	1/2	1 1/2	5 1/2	3 3/8	6 1/16	3 1/2	8 1/8	9 13/16
	5	3 1/2	3 3/4-12	2 1/2-12	3 1/2	4.249	1	3	5	3 3/8	1/2	1 1/2	5 1/2	3 3/8	6 1/16	3 1/2	8 1/8	9 13/16
	6	4	3 3/4-12	3-12	4	4.749	1	3 3/8	5 1/2	3 7/8	1/2	1 1/2	5 1/2	3 3/8	6 1/16	3 1/2	8 1/8	9 13/16
	7	4 1/2	4 1/4-12	3 1/4-12	4 1/2	5.249	1	3 7/8	6	4 3/8	1/2	1 1/2	7	3 3/8	6 1/16	3 1/2	8 1/8	9 13/16
	8	5	4 3/4-12	3 1/2-12	5	5.749	1	4 1/4	6 1/2	4 7/8	1/2	1 1/2	7	3 3/8	6 1/16	3 1/2	8 1/8	9 13/16
	9	5 1/2	5 1/4-12	4-12	5 1/2	6.249	1	4 5/8	7	5 3/8	1/2	1 1/2	7	3 3/8	6 1/16	3 1/2	8 1/8	9 13/16
	0	6	5 1/4-12	4-12	6	6.749	1	5 1/8	8	6 3/8	1/2	1 1/2	7	3 3/8	6 1/16	3 1/2	8 1/8	9 13/16
14	1(Std.)	2 1/2	2 1/4-12	1 7/8-12	3	3.124	1	2 1/16	4 1/2	2 3/8	1/2	1 1/2	4	3 3/8	6 13/16	3 13/16	9 1/4	11 1/8
	3	3	2 3/4-12	2 1/4-12	3 1/2	3.749	1	2 5/8	5	2 7/8	1/2	1 1/2	5 1/2	3 3/8	6 13/16	3 13/16	9 1/4	11 1/8
	4	3 1/2	3 3/4-12	2 1/2-12	3 1/2	4.249	1	3	5	3 3/8	1/2	1 1/2	5 1/2	3 3/8	6 13/16	3 13/16	9 1/4	11 1/8
	5	4	3 3/4-12	3-12	4	4.749	1	3 3/8	5 1/2	3 7/8	1/2	1 1/2	5 1/2	3 3/8	6 13/16	3 13/16	9 1/4	11 1/8
	6	4 1/2	4 1/4-12	3 1/4-12	4 1/2	5.249	1	3 7/8	6	4 3/8	1/2	1 1/2	7	3 3/8	6 13/16	3 13/16	9 1/4	11 1/8
	7	5	4 3/4-12	3 1/2-12	5	5.749	1	4 1/4	6 1/2	4 7/8	1/2	1 1/2	7	3 3/8	6 13/16	3 13/16	9 1/4	11 1/8
8	5 1/2	5 1/4-12	4-12	5 1/2	6.249	1	4 5/8	7	5 3/8	1/2	1 1/2	7	3 3/8	6 13/16	3 13/16	9 1/4	11 1/8	

**Dimension XI to be specified by customer.



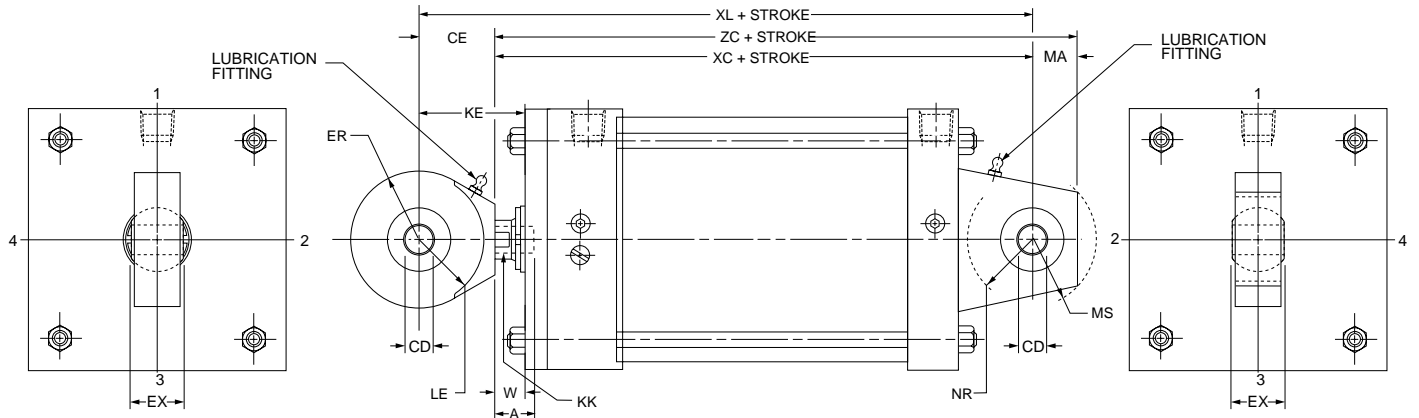

Bore	Rod No.	Rod Dia. MM	Thread		A	W	Add Stroke			KE	CD*	CE	ER	EX	LE	MA	MS	NR	Max. Oper. PSI 2A
			Style 9 KK	Style 7 KK			XC	XL	ZC										
1 1/2	1(Std.)	5/8	7/16-20	—	3/4	5/8	5 3/8	6 1/4	6 1/8	1 1/2	-.0005	7/8	13/16	7/16	3/4	3/4	15/16	5/8	250
	2	1	**	7/16-20	3/4	1	5 3/4	6 5/8	6 1/2	1 7/8	.5000								
2	1(Std.)	5/8	7/16-20	—	3/4	5/8	5 3/8	6 1/4	6 1/8	1 1/2	-.0005	7/8	13/16	7/16	3/4	3/4	15/16	5/8	250
	2	1 3/8	**	7/16-20	3/4	1 1/4	6	6 7/8	6 3/4	2 1/8	-.0005								
	3	1	**	7/16-20	3/4	1	5 3/4	6 5/8	6 1/2	1 7/8	.5000								
2 1/2	1(Std.)	5/8	7/16-20	—	3/4	5/8	5 1/2	6 3/8	6 1/4	1 1/2	-.0005	7/8	13/16	7/16	3/4	3/4	15/16	5/8	250
	2	1 3/8	**	7/16-20	3/4	1 1/2	6 3/8	7 1/4	7 1/8	2 3/8	-.0005								
	3	1	**	7/16-20	3/4	1	5 7/8	6 3/4	6 5/8	1 7/8	.5000								
	4	1 3/8	**	7/16-20	3/4	1 1/4	6 1/8	7	6 7/8	2 1/8	.5000								
3 1/4	1(Std.)	1	3/4-16	—	1 1/8	3/4	6 7/8	8 1/8	7 7/8	2	-.0005	1 1/4	1 1/8	2 1/32	1 1/16	1	1 3/8	1	250
	2	2	**	3/4-16	1 1/8	1 3/8	7 1/2	8 3/4	8 1/2	2 5/8	-.7500								
	3	1 3/8	**	3/4-16	1 1/8	1	7 1/8	8 3/8	8 1/8	2 1/4	-.0005								
	4	1 3/4	**	3/4-16	1 1/8	1 1/4	7 3/8	8 5/8	8 3/8	2 1/2	-.7500								
4	1(Std.)	1	3/4-16	—	1 1/8	3/4	6 7/8	8 1/8	7 7/8	2	-.0005	1 1/4	1 1/8	2 1/32	1 1/16	1	1 3/8	1	250
	2	2 1/2	**	3/4-16	1 1/8	1 5/8	7 3/4	9	8 3/4	2 7/8	-.0005								
	3	1 3/8	**	3/4-16	1 1/8	1	7 1/8	8 3/8	8 1/8	2 1/4	-.7500								
	4	1 3/4	**	3/4-16	1 1/8	1 1/4	7 3/8	8 5/8	8 3/8	2 1/2	-.0005								
	5	2	**	3/4-16	1 1/8	1 3/8	7 1/2	8 3/4	8 1/2	2 5/8	-.7500								
5	1(Std.)	1	3/4-16	—	1 1/8	3/4	7 1/8	8 3/8	8 1/8	2	-.0005	1 1/4	1 1/8	2 1/32	1 1/16	1	1 3/8	1	250
	2	3 1/2	**	3/4-16	1 1/8	1 5/8	8	9 1/4	9	2 7/8	-.0005								
	3	1 3/8	**	3/4-16	1 1/8	1	7 3/8	8 5/8	8 3/8	2 1/4	-.7500								
	4	1 3/4	**	3/4-16	1 1/8	1 1/4	7 5/8	8 7/8	8 5/8	2 1/2	-.0005								
	5	2	**	3/4-16	1 1/8	1 3/8	7 3/4	9	8 3/4	2 5/8	-.7500								
	6	2 1/2	**	3/4-16	1 1/8	1 5/8	8	9 1/4	9	2 7/8	-.0005								
6	1(Std.)	1 3/8	1-14	—	1 5/8	7/8	8 1/8	10	9 3/8	2 3/4	-.0005	1 7/8	1 1/4	7/8	1 7/16	1 1/4	1 11/16	1 1/4	250
	2	4	**	1-14	1 5/8	1 1/2	8 3/4	10 5/8	10	3 3/8	1.0000								
	3	1 3/4	**	1-14	1 5/8	1 1/8	8 3/8	10 1/4	9 5/8	3	-.0005								
	4	2	**	1-14	1 5/8	1 1/4	8 1/2	10 3/8	9 3/4	3 1/8	1.0000								
	5	2 1/2	**	1-14	1 5/8	1 1/2	8 3/4	10 5/8	10	3 3/8	-.0005								
	6	3	**	1-14	1 5/8	1 1/2	8 3/4	10 5/8	10	3 3/8	1.0000								
	7	3 1/2	**	1-14	1 5/8	1 1/2	8 3/4	10 5/8	10	3 3/8	1.0000								

Maximum operating pressure at 4:1 design factor is based on tensile strength of material. Pressure ratings are based on standard commercial bearing ratings.

Note: For additional dimensions see page 12.

* Dimension CD is hole diameter.

** Corresponding rod eye pin diameter may not match pin diameter of cap.

Rod No. 1 is standard.

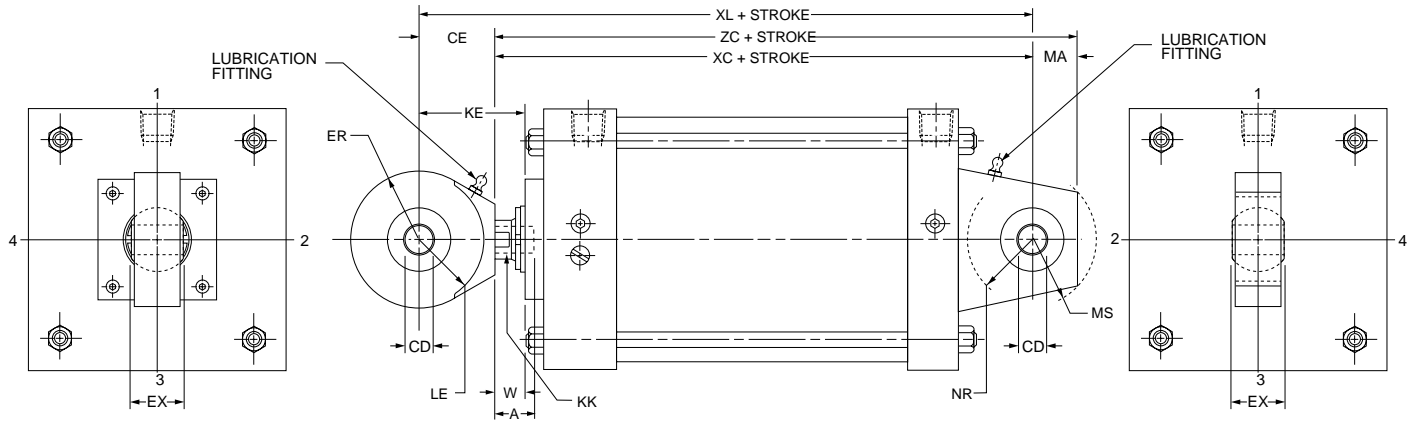

Bore	Rod No.	Rod Dia. MM	Thread		A	W	Add Stroke			KE	CD*	CE	ER	EX	LE	MA	MS	NR	Max. Oper. PSI 2A
			Style 9 KK	Style 7 KK			XC	XL	ZC										
8	1(Std.)	1 3/8	1-14	-	1 5/8	7/8	8 1/4	10 1/8	9 1/2	2 3/4	-0.0005 1.0000	1 7/8	1 1/4	7/8	1 7/16	1 1/4	1 11/16	1 1/4	250
	2	5 1/2	**	1-14	1 5/8	1 1/2	8 7/8	10 3/4	10 1/8	3 3/8									
	3	1 3/4	**	1-14	1 5/8	1 1/8	8 1/2	10 3/8	9 3/4	3									
	4	2	**	1-14	1 5/8	1 1/4	8 5/8	10 1/2	9 7/8	3 1/8									
	5	2 1/2	**	1-14	1 5/8	1 1/2	8 7/8	10 3/4	10 1/8	3 3/8									
	6	3	**	1-14	1 5/8	1 1/2	8 7/8	10 3/4	10 1/8	3 3/8									
	7	3 1/2	**	1-14	1 5/8	1 1/2	8 7/8	10 3/4	10 1/8	3 3/8									
	8	4	**	1-14	1 5/8	1 1/2	8 7/8	10 3/4	10 1/8	3 3/8									
	9	4 1/2	**	1-14	1 5/8	1 1/2	8 7/8	10 3/4	10 1/8	3 3/8									
10	1(Std.)	1 3/4	1 1/4-12	-	2	1 1/8	10 3/8	12 1/2	12 1/4	3 1/4	-0.0005 1.3750	2 1/8	1 11/16	1 3/16	1 7/8	1 7/8	2 7/16	1 5/8	250
	3	2	**	1 1/4-12	2	1 1/4	10 1/2	12 5/8	12 3/8	3 3/8									
	4	2 1/2	**	1 1/4-12	2	1 1/2	10 3/4	12 7/8	12 5/8	3 5/8									
	5	3	**	1 1/4-12	2	1 1/2	10 3/4	12 7/8	12 5/8	3 5/8									
	6	3 1/2	**	1 1/4-12	2	1 1/2	10 3/4	12 7/8	12 5/8	3 5/8									
	7	4	**	1 1/4-12	2	1 1/2	10 3/4	12 7/8	12 5/8	3 5/8									
	8	4 1/2	**	1 1/4-12	2	1 1/2	10 3/4	12 7/8	12 5/8	3 5/8									
12	1(Std.)	2	1 1/2-12	-	2 1/4	1 1/4	11 1/8	13 5/8	13 5/8	3 3/4	-0.0005 1.7500	2 1/2	2 1/16	1 17/32	2 1/8	2 1/2	2 7/8	2 1/16	250
	3	2 1/2	**	1 1/2-12	2 1/4	1 1/2	11 3/8	13 7/8	13 7/8	4									
	4	3	**	1 1/2-12	2 1/4	1 1/2	11 3/8	13 7/8	13 7/8	4									
	5	3 1/2	**	1 1/2-12	2 1/4	1 1/2	11 3/8	13 7/8	13 7/8	4									
	6	4	**	1 1/2-12	2 1/4	1 1/2	11 3/8	13 7/8	13 7/8	4									
	7	4 1/2	**	1 1/2-12	2 1/4	1 1/2	11 3/8	13 7/8	13 7/8	4									
	8	5	**	1 1/2-12	2 1/4	1 1/2	11 3/8	13 7/8	13 7/8	4									
14	1(Std.)	2 1/2	1 7/8-12	-	3	1 1/2	12 7/8	15 5/8	15 3/8	4 1/4	-0.0005 2.0000	2 3/4	2 1/2	1 3/4	2 1/2	3 5/16	2 3/8	250	
	3	3	**	1 7/8-12	3	1 1/2	12 7/8	15 5/8	15 3/8	4 1/4									
	4	3 1/2	**	1 7/8-12	3	1 1/2	12 7/8	15 5/8	15 3/8	4 1/4									
	5	4	**	1 7/8-12	3	1 1/2	12 7/8	15 5/8	15 3/8	4 1/4									
	6	4 1/2	**	1 7/8-12	3	1 1/2	12 7/8	15 5/8	15 3/8	4 1/4									
	7	5	**	1 7/8-12	3	1 1/2	12 7/8	15 5/8	15 3/8	4 1/4									

Maximum operating pressure at 4:1 design factor is based on tensile strength of material. Pressure ratings are based on standard commercial bearing ratings.

Note: For additional dimensions see page 22.

* Dimension CD is hole diameter.

** Corresponding rod eye pin diameter may not match pin diameter of cap.

Rod No. 1 is standard.

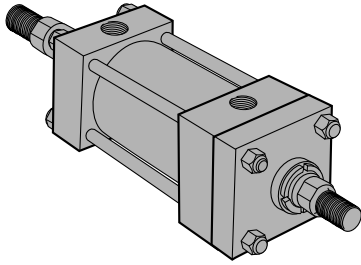

How to Use Double Rod Cylinder Dimensioned Drawings

Mounting Styles for Single Rod Models	Mounting Styles for Corresponding Double Rod Models*	Dimensions Shown on This Page Supplement Dimensions on Pages Listed Below	
		1"-6" Bores Page No.	8"-14" Bores Page No.
T	KT	4	16
TB**	KTB	4	16
TD	KTD	4	16
J	KJ	4	—
JB**	KJB	6	16
C**	KC	8	18
F	KF	8	20
D	KD	10	24
DD	KDD†	10	24

1"- 6" Bores

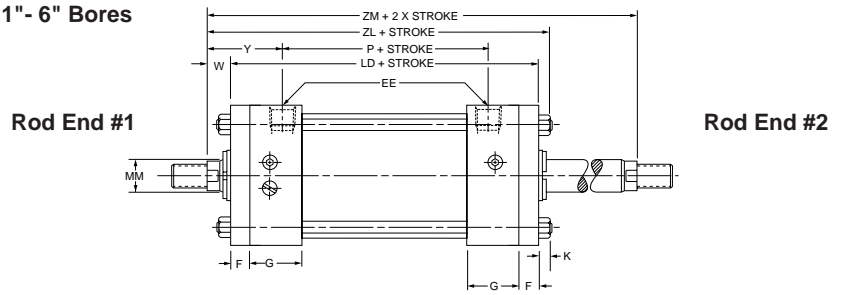

7"- 14" Bores

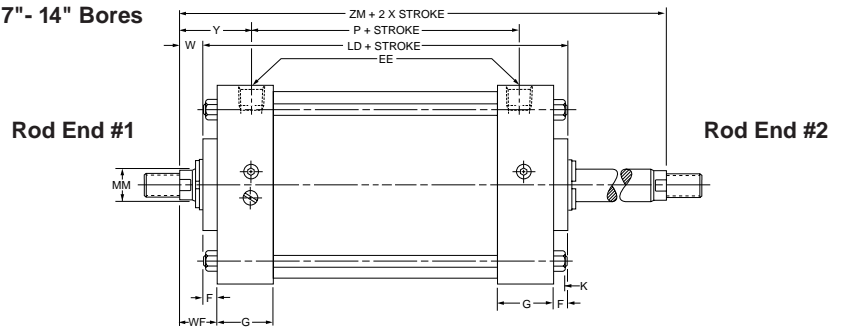

*If only one end of these Double Rod Cylinders is to be cushioned, be sure to specify clearly which end this will be.

**Available in 7" bore, pages 14-15.

†Specify XI dimension from rod end #1.

To determine dimensions for a double rod cylinder, first refer to the desired single rod mounting style cylinder shown on preceding pages of this catalog. (See table at left.) After selecting necessary dimensions from that drawing, return to this page to supplement the single rod dimensions with those shown on drawings at right and dimension table below. Note that double rod cylinders have a head (Dim. G) at both ends and that dimension LD replace LB and ZL replaces ZB, etc. The double rod dimensions differ from, or are

in addition to those for single rod cylinders shown on preceding pages and provide the information needed to completely dimension a double rod cylinder.

On a double rod cylinder where the two rod ends are different, be sure to clearly state which rod end is to be assembled at which end. Port position 1 is standard. If other than standard, specify pos. 2, 3 or 4 when viewed from rod end #1 only. See port position information on page 46.

All dimensions are in inches and apply to Code 1 rod sizes only. For alternate rod sizes, determine all envelope dimensions (within LD dim.) as described above and then use appropriate rod end dimensions for proper rod size from single rod cylinder.

Bore	Rod No.	Rod Dia. MM	Add Stroke				Add 2X Stroke
			LD	ZL	SS _K	SN _K	
1	1	1/2	4 3/4	5 1/2	3 3/8*	2 1/8	6
1 1/2	1	5/8	4 7/8	5 3/4	3 3/8	2 1/4	6 1/8
2	1	5/8	4 7/8	5 13/16	3 3/8	2 1/4	6 1/8
2 1/2	1	5/8	5	5 15/16	3 1/2	2 3/8	6 1/4
3 1/4	1	1	6	7 1/8	3 3/4	2 5/8	7 1/2
4	1	1	6	7 1/8	3 3/4	2 5/8	7 1/2
5	1	1	6 1/4	7 7/16	3 5/8	2 7/8	7 3/4
6	1	1 3/8	7	8 5/16	4 1/8	3 1/8	8 3/4
7	1	1 3/8	7 1/8	—	4 1/4	3 1/4	8 7/8
8	1	1 3/8	7 1/8	—	4 1/4	3 1/4	8 7/8
10	1	1 3/4	8 1/8	—	4 7/8	4 1/8	10 3/8
12	1	2	8 5/8	—	5 3/8	4 5/8	11 1/8
14	1	2 1/2	10 1/8	—	6 3/8	5 1/2	13 1/8
Replaces: On single rod mounting styles:			LB	ZB	SS	SN	—
			All Mtg. Styles		C	F	All Mtgs.

* Mounting style KDD not available in 1" and 7" bore sizes.

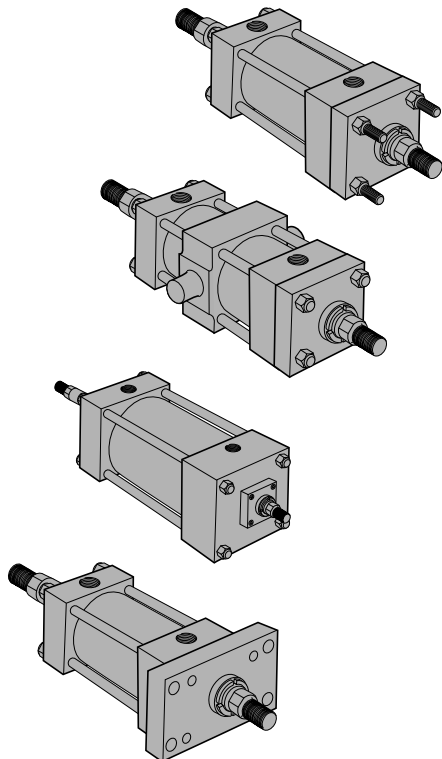

Parker offers a complete range of Cylinder Accessories to assure you of the greatest versatility in present or future cylinder applications. Accessories offered for spherical bearing mount

cylinders include the Rod Eye, Pivot Pin and Clevis Bracket. To select the proper part number for any desired accessory refer to the tables below.

Spherical Rod Eye Dimensions

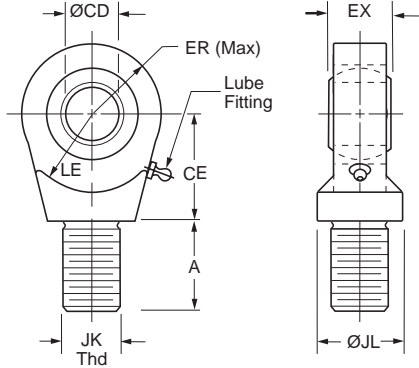

Bore Ø	Part Number	CD Ø	A	CE	EX	ER	LE	JK Thread	JL Ø	Load Capacity (lb)
1.50, 2.00, 2.50	0961000050	.5000 ⁻⁰⁰⁰⁵	0.72	0.86	0.44	0.80	0.78	7/16-20	0.88	2644
3.25, 4.00, 5.00	0961000075	.7500 ⁻⁰⁰⁰⁵	1.02	1.25	0.66	1.14	1.06	3/4-16	1.31	9441
6.00, 8.00	0961000100	1.0000 ⁻⁰⁰⁰⁵	1.52	1.88	0.88	1.34	1.45	1-14	1.50	16860
10.00	0961000138	1.3750 ⁻⁰⁰⁰⁵	2.02	2.13	1.19	1.67	1.91	1 1/4-12	2.00	28562
12.00	0961000175	1.7500 ⁻⁰⁰⁰⁵	2.14	2.50	1.53	2.05	2.16	1 1/2-12	2.00	43005
14.00	0961000200	2.0000 ⁻⁰⁰⁰⁵	2.89	2.75	1.75	2.60	2.50	1 7/8-12	2.75	70193

Order to fit Piston Rod Thread Size.

Pivot Pin Dimensions

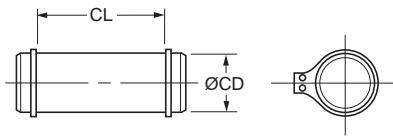

Bore Ø	Part Number	CD Ø	CL	Shear Capacity (lb)
1.50, 2.00, 2.50	0839620000	.4997 ⁻⁰⁰⁰⁴	1.56	8600
3.25, 4.00, 5.00	0839630000	.7497 ⁻⁰⁰⁰⁵	2.03	19300
6.00, 8.00	0839640000	.9997 ⁻⁰⁰⁰⁵	2.50	34300
10.00	0839650000	1.3746 ⁻⁰⁰⁰⁶	3.31	65000
12.00	0839660000	1.7496 ⁻⁰⁰⁰⁶	4.22	105200
14.00	0839670000	1.9996 ⁻⁰⁰⁰⁷	4.94	137400

Pivot Pins are furnished with (2) Retainer Rings.

Clevis Bracket Dimensions

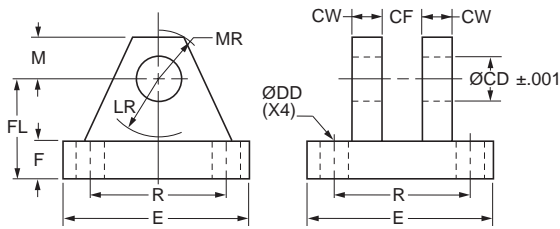

Fabricated Steel

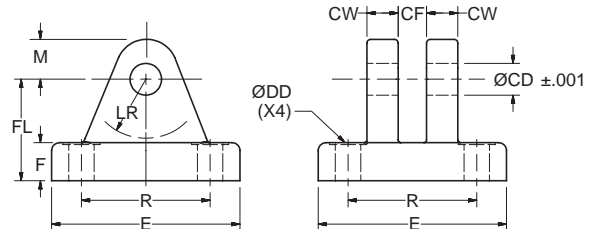

Cast Ductile Iron

Order to fit Cylinder Cap or Rod Eye.

Bore Ø	Pin Ø	Cast Ductile Iron Part Number	Fabricated Steel Part Number	CD Ø	CF	CW	DD Ø	E	F	FL	LR	M	MR	R	Load Capacity (lb)
1.50, 2.00, 2.50	0.500	0959450000	0839470000	0.503	0.45	0.50	0.41	3.00	0.50	1.50	0.94	0.50	0.63	2.05	5770
3.25, 4.00, 5.00	0.750	0959300000	0839480000	0.753	0.67	0.63	0.53	3.75	0.63	2.00	1.38	0.88	1.00	2.76	9450
6.00, 8.00	1.000	0959310000	0839490000	1.003	0.89	0.75	0.53	5.50	0.75	2.50	1.69	1.00	1.19	4.10	14300
10.00	1.375	0959320000	0839500000	1.378	1.20	1.00	0.66	6.50	0.88	3.50	2.44	1.38	1.63	4.95	20322
12.00	1.750	0959330000	0839510000	1.753	1.55	1.25	0.91	8.50	1.25	4.50	2.88	1.75	2.06	6.58	37800
14.00	2.000	0959340000	0839520000	2.003	1.77	1.50	0.91	10.63	1.50	5.00	3.00	2.00	2.38	7.92	50375

Cylinder Accessories

Parker offers a complete range of cylinder accessories to assure flexibility and versatility in present or future cylinder applications.

Rod End Accessories

Accessories offered for the rod end of the cylinder include: Rod Clevis, Eye Bracket, Knuckle, Clevis Bracket and Pivot Pin. To select the proper part number for any desired accessory, refer to Chart A below and look opposite the thread size of the rod end as indicated in the first column. The Pivot Pins, Eye Brackets and Clevis Brackets are listed opposite the thread size which their mating Knuckles or Clevises fit.

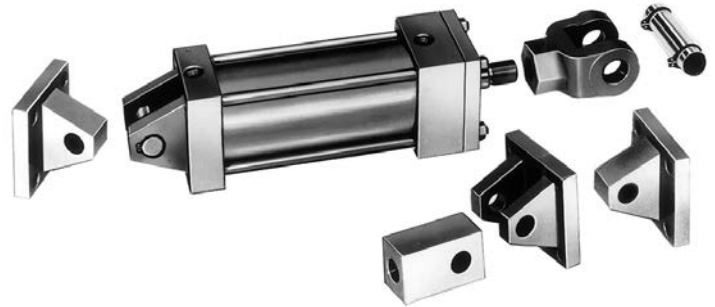

Accessory Load Capacity

The various accessories on this and the following pages have been load rated for your convenience. The load capacity shown in lbs. is the recommended maximum load for that accessory based on a 4:1 design factor in tension. (Pivot Pin is rated in shear.) Before specifying, compare

the actual load or the tension (pull) force at maximum operating pressure of the cylinder with the load capacity of the accessory you plan to use. If load or pull force of cylinder exceeds load capacity of accessory, consult factory.

Chart A

Thread Size	Pin Ø	Rod Clevis		Mounting Plate or Eye Bracket		Pivot Pin	
		Part Number	Load Capacity (lb)	Forged Steel or Cast Ductile Iron		Part Number	Shear Capacity (lb)
				Part Number	Load Capacity (lb)		
5/16-24	0.312	0512210000 ¹	2600	0959810031	1850	—	—
7/16-20	0.500	0509400000	4250	0959810050 ²	4620	0683680000	8600
1/2-20	0.500	0509410000	4900	0959810050 ²	4620	0683680000	8600
3/4-16	0.750	0509420000	11200	0959810075 ²	12370	0683690000	19300
3/4-16	0.750	1332840000	11200	0959810075 ²	12370	0683690000	19300
7/8-14	1.000	0509430000	18800	0959810100 ²	20450	0683700000	34300
1-14	1.000	0509440000	19500	0959810100 ²	20450	0683700000	34300
1-14	1.000	1332850000	19500	0959810100 ²	20450	0683700000	34300
1 1/4-12	1.375	0509450000	33500	0959810138	33500	0683710000	65000
1 1/4-12	1.375	1332860000	33500	0959810138	33500	0683710000	65000
1 1/2-12	1.750	0509460000	45600	0959810175	49480	0683720000	105200
1 3/4-12	2.000	0509470000	65600	0959810200 ²	70100	0683730000	137400
1 7/8-12	2.000	0509480000	65600	0959810200 ²	70100	0683730000	137400
2 1/4-12	2.500	0509490000	98200	0959810250 ²	98200	0683740000	214700
2 1/2-12	3.000	0509500000	98200	0959810300 ²	121940	0683750000	309200
2 3/4-12	3.000	0509510000	98200	0959810300 ²	121940	0683750000	309200
3 1/4-12	3.500	0509520000	156700	0959810350	187910	0735450000	420900
3 1/2-12	4.000	0509530000	193200	0959810400	268000	0735470000	565800
4-12	4.000	0509540000	221200	0959810400	268000	0735470000	565800

¹ Includes pivot pin.

² Cylinder accessory dimensions conform to ANSI/NFPA/T3.6.8 R3-2010.

Mounting Plates

Mounting Plates for Style BB (clevis mounted) cylinders are offered. To select proper part number for your application, refer to Chart B at right.

Chart B

Series 2A	
Mounting Plate Part Number	Bore Ø
0960160044	1.00
0959810050	1.50, 2.00, 2.50
0959810075	3.25, 4.00, 5.00
0959810100	6.00, 7.00, 8.00
0959810138	10.00
0959810175	12.00
0959810200	14.00

Rod Clevis Dimensions

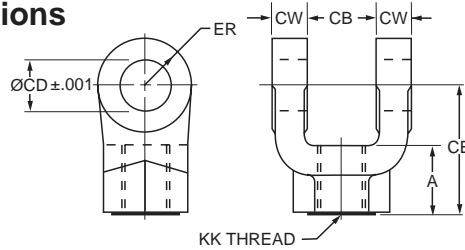

Pivot Pin Dimensions

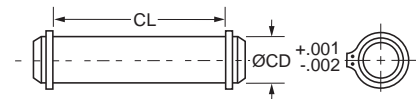

Part Number ¹	Pin Ø	A	CB	CD Ø	CE	CW	ER	KK Thread
0512210000 ²	0.310	0.81	0.34	0.314	2.25	0.20	0.30	5/16-24
0509400000	0.500	0.75	0.77	0.503	1.50	0.49	0.50	7/16-20
0509410000	0.500	0.75	0.77	0.503	1.50	0.49	0.50	1/2-20
0509420000	0.750	1.13	1.27	0.753	2.13	0.62	0.75	3/4-16
1332840000	0.750	1.13	1.27	0.753	2.38	0.62	0.75	3/4-16
0509430000	1.000	1.63	1.52	1.003	2.94	0.74	1.00	7/8-14
0509440000	1.000	1.63	1.52	1.003	2.94	0.74	1.00	1-14
1332850000	1.000	1.63	1.52	1.003	3.13	0.74	1.00	1-14
0509450000	1.375	1.88	2.04	1.378	3.75	0.99	1.38	1 1/4-12
1332860000	1.375	2.00	2.04	1.378	4.13	0.99	1.38	1 1/4-12
0509460000	1.750	2.25	2.54	1.753	4.50	1.24	1.75	1 1/2-12
0509470000	2.000	3.00	2.54	2.003	5.50	1.24	2.00	1 3/4-12
0509480000	2.000	3.00	2.54	2.003	5.50	1.24	2.00	1 7/8-12
0509490000	2.500	3.50	3.04	2.503	6.50	1.49	2.50	2 1/4-12
0509500000	3.000	3.50	3.04	3.003	6.75	1.49	2.75	2 1/2-12
0509510000	3.000	3.50	3.04	3.003	6.75	1.49	2.75	2 3/4-12
0509520000	3.500	3.50 ³	4.04	3.503	7.75	1.98	3.50	3 1/4-12
0509530000	4.000	4.00 ³	4.54	4.003	8.81	2.23	4.00	3 1/2-12
0509540000	4.000	4.00 ³	4.54	4.003	8.81	2.23	4.00	4-12

Part Number	CD Ø	CL
0683680000	0.500	1.88
0683690000	0.750	2.63
0683700000	1.000	3.13
0683710000	1.375	4.19
0683720000	1.750	5.19
0683730000	2.000	5.19
0683740000	2.500	6.19
0683750000	3.000	6.25
0735450000	3.500	8.25
0735470000 ⁴	4.000	9.00

⁴ This size supplied with cotter pins.

1. Pivot Pins are furnished with Clevis Mounted Cylinders as standard.
2. Pivot Pins are furnished with (2) Retainer Rings.
3. Pivot Pins must be ordered as a separate item if to be used with Knuckles, Rod Clevises, or Clevis Brackets.

¹ Rod Clevises with pin diameters 0.312 thru 1.375 are forged steel. Rod Clevises with 1.750 pin diameter and larger are cast ductile iron.

² Includes Pivot Pin

³ Consult appropriate cylinder rod end dimensions for compatibility.

Forged Steel or Cast Ductile Iron Mounting Plate or Eye Bracket Dimensions⁵

Note: Cast ductile iron eye brackets must not be welded in place.

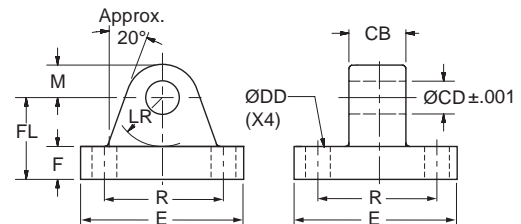

Cast or Forged ⁶ Part Number	Pin Ø	CB	CD Ø	DD Ø	E (As Cast)	F	FL	LR	M (As Cast)	R
0959810031	0.312	0.31	0.314	0.27	2.25	0.38	1.00	0.59	0.38	1.75
0959810050	0.500	0.75	0.503	0.41	2.50	0.38	1.13	0.69	0.50	1.63
0959810075	0.750	1.25	0.753	0.53	3.50	0.63	1.88	1.13	0.75	2.55
0959810100	1.000	1.50	1.003	0.66	4.50	0.88	2.38	1.37	1.00	3.25
0959810138	1.375	2.00	1.378	0.66	5.00	1.00 ⁷	3.00	1.88	1.38	3.82
0959810175	1.750	2.50	1.753	0.91	6.50	1.25 ⁷	3.38	2.13	1.75	4.95
0959810200	2.000	2.50	2.003	1.06	7.50	1.50	4.00	2.38	2.00	5.73
0959810250	2.500	3.00	2.503	1.19	8.50	1.75	4.75	2.88	2.50	6.58
0959810300	3.000	3.00	3.003	1.31	9.50	2.00	5.25	3.13	3.00	7.50
0959810350	3.500	4.00	3.503	1.81	12.63	2.50 ⁸	6.50 ⁸	3.88	3.50	9.62
0959810400	4.000	4.50	4.003	2.06	14.88	3.00 ⁸	7.50 ⁸	4.38	4.06	11.45

⁵ When used to mate with the Rod Clevis, select by pin diameter in the table above.

⁶ Eye Brackets with pin diameters 0.500 thru 1.000 are forged steel. Eye Brackets with 0.312 and 1.375 pin diameter and larger are cast ductile iron.

⁷ These dimensions vary from NFPA standard. F is increased by 0.13. Sufficient LR clearance remains for full swing arc with Parker cap clevis cylinders and rod clevises.

⁸ Mounting base thickness dimension F is increased on these sizes to provide greater load capacity than the former fabricated steel design. Cast ductile iron dimensions F and FL are 0.81 larger for 3.500 pin diameter and 1.06 larger for 4.000 pin diameter.

Rod End Accessories

Accessories offered for the rod end of the cylinder include Rod Clevis, Eye Bracket, Knuckle, Clevis Bracket, and Pivot Pin. To select the proper part number for any desired accessory, refer to the table below or on the opposite page and look in the row to the right of the rod thread in the first column. For economical accessory selection, it is recommended that rod end style 4 be specified on your cylinder order.

Accessory Load Capacity

The various accessories have been load rated for your convenience. The load Capacity in lbs. is the recommended maximum load for that accessory based on a 4:1 design factor in tension. (Pivot Pin is rated in shear.) Before specifying, compare the actual load or the tension (pull) force at the maximum operating pressure of the cylinder with the load capacity of the accessory you plan to use. If load or pull force of cylinder exceeds load capacity of accessory, consult factory.

Thread Size	Pin Ø	Knuckle		Clevis Bracket				Pivot Pin	
		Part Number	Load Capacity (lb)	Forged Steel or Cast Ductile Iron		Fabricated Steel		Part Number	Shear Capacity (lb)
				Part Number	Load Capacity (lb)	Part Number	Load Capacity (lb)		
5/16-24	0.438	0740750000	3300	0960160044	2830	0740760000	3600	0740780000	6600
7/16-20	0.500	0690890000	5000	0960160050	7740	0692050000	7300	0683680000	8600
1/2-20	0.500	0690900000	5700	0960160050	7740	0692050000	7300	0683680000	8600
3/4-16	0.750	0690910000	12100	0960160075	13600	0692060000	10880	0683690000	19300
7/8-14	1.000	0690920000	13000	0960160100	23000	0692070000	15180	0683700000	34300
1-14	1.000	0690930000	21700	0960160100	23000	0692070000	15180	0683700000	34300
1 1/4-12	1.375	0690940000	33500	0960160138	39500	0692080000	23560	0683710000	65000
1 1/2-12	1.750	0690950000	45000	0960160175	49480	0692090000	21520	0683720000	105200
1 3/4-12	2.000	0690960000	53500	0960160200	72400	0692100000	26000	0692150000	137400
1 7/8-12	2.000	0962160000	75000	0960160200	72400	0692100000	26000	0692150000	137400
2 1/4-12	2.500	0962170000	98700	0960160250	98700	0692110000	28710	0683740000	214700
2 1/2-12	3.000	0962180000	110000	0960160300	123300	0692120000	28190	0683750000	309200
2 3/4-12	3.000	0962190000	123300	N/A	N/A	0692130000	31390	0692160000	309200
3 1/4-12	3.500	0962200000	161300	0960160350	200400	0735420000	80250	0735450000	420900
3 1/2-12	3.500	0962210000	217300	0960160350	200400	0735420000	80250	0735450000	420900
4-12	4.000	0962220000	273800	0960160400	292100	0735430000	98420	0821810000	565800
N/A	4.000	N/A	N/A	N/A	N/A	N/A	N/A	0735470000 ¹	565800

¹ This size supplied with cotter pins.

Forged Steel or Cast Ductile Iron Clevis Bracket Dimensions

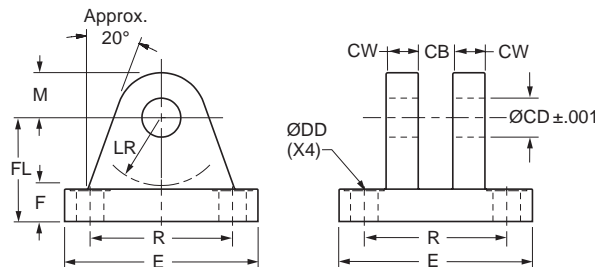

Note: Cast ductile iron clevis brackets must not be welded in place.

Cast or Forged ² Part Number	Pin Ø	CB	CD Ø	CW	DD Ø	E (As Cast)	F	FL	LR	M (As Cast)	R
0960160044	0.438	0.46	0.440	0.37	0.27	2.25	0.38	1.00	0.56	0.44	1.75
0960160050	0.500	0.78	0.503	0.50	0.41	2.50	0.38	1.13	0.63	0.56	1.63
0960160075	0.750	1.28	0.753	0.63	0.53	3.50	0.63	1.88	1.06	0.75	2.56
0960160100	1.000	1.53	1.003	0.75	0.66	4.50	0.75	2.25	1.25	1.00	3.25
0960160138	1.375	2.03	1.378	1.00	0.66	5.00	0.88	3.00	1.94	1.38	3.81
0960160175	1.750	2.53	1.753	1.25	0.91	6.50	0.94	3.13	2.00	1.75	4.94
0960160200	2.000	2.53	2.003	1.25	1.06	7.50	1.38	3.75	2.25	2.00	5.75
0960160250	2.500	3.03	2.503	1.50	1.19	8.50	1.50	4.50	2.81	2.50	6.59
0960160300	3.000	3.03	3.003	1.50	1.31	9.50	1.88	5.38	3.31	3.00	7.50
0960160350	3.500	4.03	3.503	2.00	1.81	12.63	2.31	6.38	3.88	3.50	9.62
0960160400	4.000	4.53	4.003	2.25	2.06	14.88	2.88	7.50	4.50	4.00	11.50

² Clevis Brackets with pin diameters 0.500 thru 1.000 are forged steel. Clevis Brackets with 0.438 and 1.375 pin diameter and larger are cast ductile iron.

Knuckle Dimensions

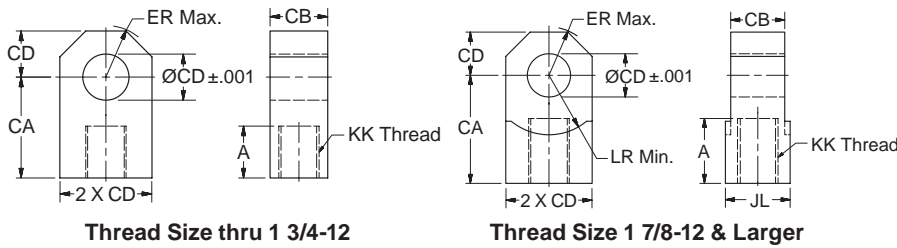

Pivot Pin Dimensions

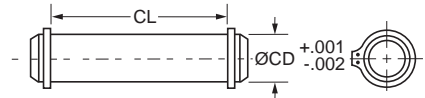

Part Number	CD Ø	CL
0740780000	0.438	1.31
0683680000	0.500	1.88
0683690000	0.750	2.63
0683700000	1.000	3.13
0683710000	1.375	4.19
0683720000	1.750	5.19
0692150000	2.000	5.69
0683740000	2.500	6.19
0683750000	3.000	6.25
0692160000	3.000	6.75
0735450000	3.500	8.25
0821810000	4.000	8.69
0735470000 ¹	4.000	9.00

¹This size supplied with cotter pins.

1. Pivot Pins are furnished with Clevis Mounted Cylinders as standard.
2. Pivot Pins are furnished with (2) Retainer Rings.
3. Pivot Pins must be ordered as a separate item if to be used with Knuckles, Rod Clevises, or Clevis Brackets.

Part Number	Pin Ø	A	CA	CB	CD Ø	ER	JL	LR min	KK Thread
0740750000	0.438	0.75	1.50	0.43	0.440	0.53	-	-	5/16-24
0690890000	0.500	0.75	1.50	0.75	0.503	0.59	-	-	7/16-20
0690900000	0.500	0.75	1.50	0.75	0.503	0.59	-	-	1/2-20
0690910000	0.750	1.13	2.06	1.25	0.753	0.87	-	-	3/4-16
0690920000	1.000	1.13	2.38	1.50	1.003	1.15	-	-	7/8-14
0690930000	1.000	1.63	2.81	1.50	1.003	1.15	-	-	1-14
0690940000	1.375	2.00	3.44	2.00	1.378	1.55	-	-	1 1/4-12
0690950000	1.750	2.25	4.00	2.50	1.753	1.96	-	-	1 1/2-12
0690960000	2.000	2.25	4.38	2.50	2.003	2.24	-	-	1 3/4-12
0962160000	2.000	3.00	5.00	2.50	2.003	2.24	3.00	2.77	1 7/8-12
0962170000	2.500	3.50	5.81	3.00	2.503	2.76	3.50	3.09	2 1/4-12
0962180000	3.000	3.50	6.13	3.00	3.003	3.30	4.00	3.58	2 1/2-12
0962190000	3.000	3.63	6.50	3.50	3.003	3.30	4.00	3.58	2 3/4-12
0962200000	3.500	4.50	7.63	4.00	3.503	3.87	6.00	4.18	3 1/4-12
0962210000	3.500	5.00	7.63	4.00	3.503	3.87	6.00	4.18	3 1/2-12
0962220000	4.000	5.50	9.13	4.50	4.003	4.43	6.00	4.80	4-12

Fabricated Steel Clevis Bracket Dimensions

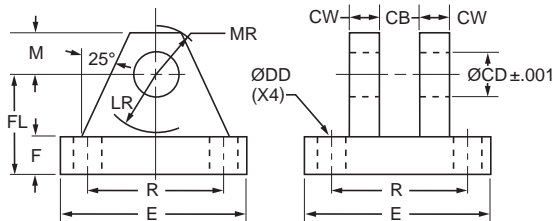

Fabricated Steel Part Number	Pin ² Ø	CB	CD Ø	CW	DD Ø	E	F	FL	LR	M	MR	R
0692050000	0.500	0.80	0.503	0.50	0.41	3.50	0.50	1.50	0.75	0.50	0.63	2.55
0692060000	0.750	1.30	0.753	0.63	0.53	5.00	0.63	1.88	1.19	0.75	0.91	3.82
0692070000	1.000	1.59	1.003	0.75	0.66	6.50	0.75	2.25	1.50	1.00	1.25	4.95
0692080000	1.375	2.09	1.378	1.00	0.66	7.50	0.88	3.00	2.00	1.38	1.66	5.73
0692090000	1.750	2.59	1.753	1.25	0.91	9.50	0.88	3.63	2.75	1.75	2.22	7.50
0692100000	2.000	2.59	2.003	1.50	1.06	12.75	1.00	4.25	3.19	2.25	2.78	9.40
0692110000	2.500	3.09	2.503	1.50	1.19	12.75	1.00	4.50	3.50	2.50	3.13	9.40
0692120000	3.000	3.09	3.003	1.50	1.31	12.75	1.00	6.00	4.25	3.00	3.59	9.40
0692130000	3.000	3.59	3.003	1.50	1.31	12.75	1.00	6.00	4.25	3.00	3.59	9.40
0735420000	3.500	4.09	3.503	2.00	1.81	15.50	1.69	6.69	5.00	3.50	4.13	12.00
0735430000	4.000	4.59	4.003	2.00	2.06	17.50	1.94	7.69	5.75	4.00	4.88	13.75

² Clevis Bracket for 0.438 diameter pin is only available in cast ductile iron construction. See part number 0960160044 on previous page.

Dual Axis Knuckle

Using a Dual Axis Knuckle permits increased angular movement from the cylinder center line. Clevis or Eye mounted cylinders often require movement beyond the plane that two pivot pins allow. Spherical bearing mounts permit angular movement up to 4.5° within the pivoting plane. A Dual Axis Knuckle, with two pin holes 90° apart, installed at the cap and rod end of a mounting style BB cylinder adds two pivot points, thereby providing up to 30° movement in another plane at each end.

Dual Axis Knuckle Benefits

- Increased angular movement range compared to spherical bearing mount.
- Significantly higher dynamic load rating than spherical bearing mount.
- Reduced bearing loads and wear that results from misalignment.
- Allows faster assembly of pivoting cylinders to the machine.

Maximum Achievable Angular Movement from Cylinder Centerline¹

Inboard Pin -

15° maximum movement for cylinder misalignment only.

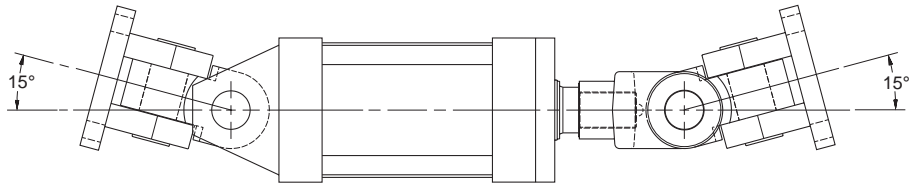

Outboard Pin -

30° maximum movement when applying force to a load moving in a curved plane.

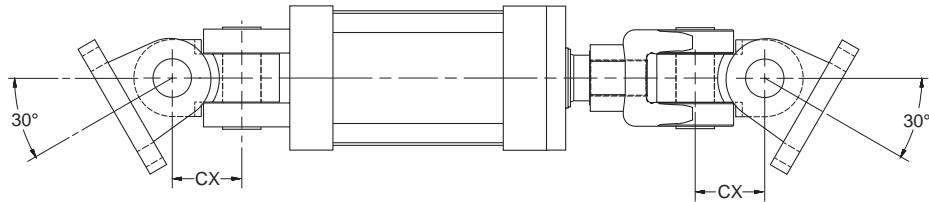

¹ Maximum movement is achieved with cast clevis brackets. Movement is reduced when using fabricated clevis brackets.

Dual Axis Knuckle Dimensions and Usage

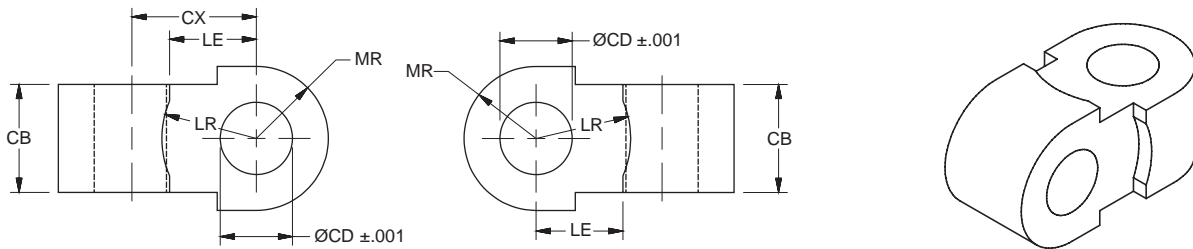

Part Number	Pin Ø	Load Capacity (lb)	CB	CD Ø	CX	LE	LR	MR	Mating Parts		BB Mount Usage by Series & Bore 2A
									Clevis Bracket	Rod Clevis	
0952670000	0.500	4380	0.75	0.503	0.88	0.54	0.63	0.50	0960160050	0509400000, 0509410000	1.50, 2.00, 2.50
0952680000	0.750	12370	1.25	0.753	1.19	0.80	0.94	0.75	0960160075	0509420000, 1332840000	3.25, 4.00, 5.00
0952690000	1.000	20500	1.50	1.003	1.69	1.05	1.22	1.00	0960160100	0509430000, 0509440000, 1332850000	6.00, 7.00, 8.00
0952700000	1.375	30500	2.00	1.378	2.38	1.44	1.69	1.38	0960160138	0509450000, 1332860000	10.00
0952710000	1.750	49500	2.50	1.753	3.06	1.81	2.19	1.75	0960160175	0509460000	12.00
0952720000	2.000	68000	2.50	2.003	3.63	2.09	2.44	2.00	0960160200	0509470000, 0509480000	14.00

Linear Alignment Couplers



- Simplify Cylinder Installation
- Reduce Assembly Time
- Increase Cylinder Bearing and Seal Life
- Reliable Performance In “Push” *and* “Pull” Applications

Linear Alignment Couplers are available in 19 standard thread sizes...

Cost Saving Features and Benefits Include...

- Maximum reliability for trouble-free operation, long life and lower operating costs
- Increased cylinder life by reducing wear on Piston and Rod bearings
- Simplifying Cylinder installation and reducing assembly costs
- Increase Rod Bearing and Rod Seal life for lower maintenance costs

Alignment Coupler

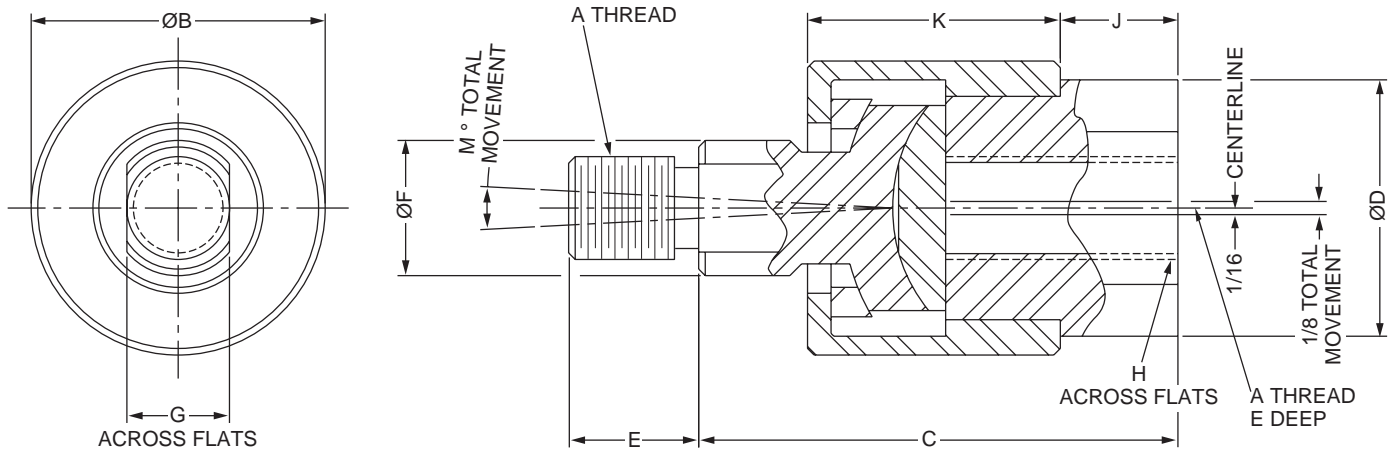

Part Numbers and Dimensions

Part Number	A	B \varnothing	C	D \varnothing	E	F \varnothing	G	H	J	K	M	Max. Pull Load (lbs.)	Max. Approx. Weight (lbs.)
1347570031	5/16-24	1.13	1.75	0.94	0.50	0.50	0.38	0.75	0.38	0.94	6°	1200	.35
1347570038	3/8-24	1.13	1.75	0.94	0.50	0.50	0.38	0.75	0.38	0.94	6°	2425	.35
1347570044	7/16-20	1.38	2.00	1.13	0.75	0.63	0.50	0.88	0.38	1.09	6°	3250	.55
1347570050	1/2-20	1.38	2.00	1.13	0.75	0.63	0.50	0.88	0.38	1.09	6°	4450	.55
1347570063	5/8-18	1.38	2.00	1.13	0.75	0.63	0.50	0.88	0.38	1.09	6°	6800	.55
1347570075	3/4-16	2.00	2.31	1.63	1.13	0.94	0.75	1.31	0.44	1.28	6°	9050	1.4
1347570088	7/8-14	2.00	2.31	1.63	1.13	0.94	0.75	1.31	0.44	1.28	6°	14450	1.4
1347570100	1-14	3.13	3.00	2.38	1.63	1.44	1.25	1.88	0.75	1.78	6°	19425	4.8
1347570125	1 1/4-12	3.13	3.00	2.38	1.63	1.44	1.25	1.88	0.75	1.78	6°	30500	4.8
1337390125	1 1/4-12	3.50	4.00	2.00	2.00	1.50	1.25	1.69	0.75	2.50	10°	30500	6.9
1337390150	1 1/2-12	4.00	4.38	2.25	2.25	1.75	1.50	1.94	0.88	2.75	10°	45750	9.8
1337390175	1 3/4-12	4.00	4.38	2.25	2.25	1.75	1.50	1.94	0.88	2.75	10°	58350	9.8
1337390188	1 7/8-12	5.00	5.63	3.00	3.00	2.25	2.00	2.63	1.38	3.38	10°	67550	19.8
1337390200	2-12	5.00	5.63	3.00	3.00	2.25	2.00	2.63	1.38	3.38	10°	77450	19.8
1337390225	2 1/4-12	6.75	6.38	3.25	3.50	2.75	2.38	2.88	1.63	3.75	10°	99250	35.3
1337390250	2 1/2-12	7.00	6.50	4.00	3.50	3.25	2.88	3.38	1.63	3.88	10°	123750	45.3
1337390275	2 3/4-12	7.00	6.50	4.00	3.50	3.25	2.88	3.38	1.63	3.88	10°	150950	45.3
1337390300	3-12	7.00	6.50	4.00	3.50	3.25	2.88	3.38	1.63	3.88	10°	180850	45.3
1337390325	3 1/4-12	9.25	8.50	5.25	4.50	4.00	3.38	4.50	2.00	5.50	10°	213450	—
1337390425	4 1/4-12	12.88	11.25	7.75	4.50	5.50	4.88	7.00	1.50	8.75	10°	370850	—

How to Order Linear Alignment Couplers — When ordering a cylinder with a threaded male rod end, specify the coupler of equal thread size by part number as listed in Table 1, i.e.; Piston Rod “KK” or “CC” dimension is 3/4" - 16", specify coupler part number 1347570075.

Parker “Style 55” Piston Rod End

Dimensions Style 55 Rod End

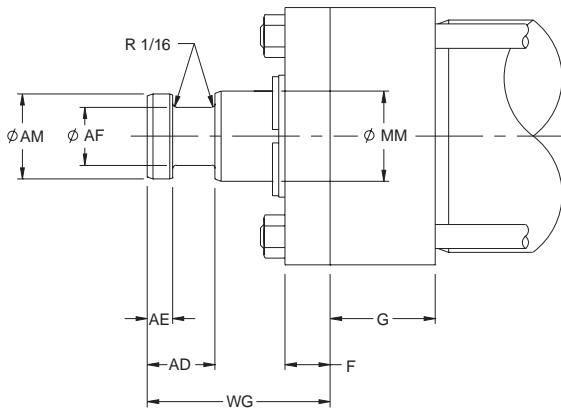

MM Rod Dia.	AD	AE	AF	AM	WG
$\frac{5}{8}$	$\frac{5}{8}$	$\frac{1}{4}$	$\frac{3}{8}$.57	$1\frac{3}{4}$
1	$\frac{15}{16}$	$\frac{3}{8}$	$\frac{11}{16}$.95	$2\frac{3}{8}$
$1\frac{3}{8}$	$1\frac{1}{16}$	$\frac{3}{8}$	$\frac{7}{8}$	1.32	$2\frac{3}{4}$
$1\frac{3}{4}$	$\frac{15}{16}$	$\frac{1}{2}$	$1\frac{1}{8}$	1.70	$3\frac{1}{8}$
2	$1\frac{11}{16}$	$\frac{5}{8}$	$1\frac{3}{8}$	1.95	$3\frac{3}{4}$
$2\frac{1}{2}$	$1\frac{15}{16}$	$\frac{3}{4}$	$1\frac{3}{4}$	2.45	$4\frac{1}{2}$
3	$2\frac{7}{16}$	$\frac{7}{8}$	$2\frac{1}{4}$	2.95	$4\frac{7}{8}$
$3\frac{1}{2}$	$2\frac{11}{16}$	1	$2\frac{1}{2}$	3.45	$5\frac{5}{8}$
4	$2\frac{11}{16}$	1	3	3.95	$5\frac{3}{4}$
$4\frac{1}{2}$	$3\frac{3}{16}$	$1\frac{1}{2}$	$3\frac{1}{2}$	4.45	$6\frac{1}{2}$
5	$3\frac{3}{16}$	$1\frac{1}{2}$	$3\frac{7}{8}$	4.95	$6\frac{5}{8}$
$5\frac{1}{2}$	$3\frac{15}{16}$	$1\frac{7}{8}$	$4\frac{3}{8}$	5.45	$7\frac{1}{2}$

See mounting dimension pages for F and G

Split Couplers and Weld Plates

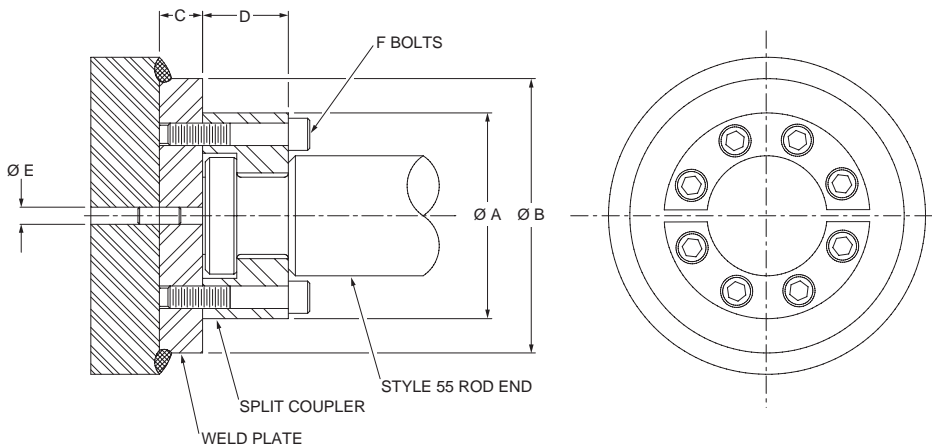

⚠ WARNING: Piston rod separation from the machine member can result in severe personal injury or even death to nearby personnel. The cylinder user must make sure the weld holding the weld plate to the machine is of sufficient quality and size to hold the intended load. The cylinder user must also make sure the bolts holding split coupler to the weld plate are of sufficient strength to hold the intended load and installed in such a way that they will not become loose during the machine's operation.

Part Numbers and Dimensions

Rod Ø	A Ø	B Ø	C	D	E Ø	F	Bolt Size	Bolt Circle	Split Coupler Part Number	Weld Plate Part Number
0.625	1.50	2.00	.50	.56	.250	4	#10-24 x .94 LG	1.125	147234 0062	148174 0062
1.000	2.00	2.50	.50	.88	.250	6	.250-20 x 1.25 LG	1.500	147234 0100	148174 0100
1.375	2.50	3.00	.63	1.00	.250	6	.312-18 x 1.50 LG	2.000	147234 0138	148174 0138
1.750	3.00	4.00	.63	1.25	.250	8	.312-18 x 1.75 LG	2.375	147234 0175	148174 0175
2.000	3.50	4.00	.75	1.63	.375	12	.375-16 x 2.25 LG	2.687	147234 0200	148174 0200
2.500	4.00	4.50	.75	1.88	.375	12	.375-16 x 2.50 LG	3.187	147234 0250	148174 0250
3.000	5.00	5.50	1.00	2.38	.375	12	.500-13 x 3.25 LG	4.000	147234 0300	148174 0300
3.500	5.88	7.00	1.00	2.63	.375	12	.625-11 x 3.50 LG	4.687	147234 0350	148174 0350
4.000	6.38	7.00	1.00	2.63	.375	12	.625-11 x 3.50 LG	5.187	147234 0400	148174 0400
4.500	6.88	8.00	1.00	3.13	.375	12	.625-11 x 4.00 LG	5.687	147234 0450	148174 0450
5.000	7.38	8.00	1.00	3.13	.375	12	.625-11 x 4.00 LG	6.187	147234 0500	148174 0500
5.500	8.25	9.00	1.25	3.88	.375	12	.750-10 x 5.00 LG	6.875	147234 0550	148174 0550

Note: Bolts are not included with split coupler or weld plate.

How to Order Series “2A” Cylinders

When ordering Series 2A cylinders, please review the following:

Note: Duplicate cylinders can be ordered by giving the SERIAL NUMBER from the nameplate of the original cylinder. Factory records supply a quick positive identification.

Piston Rods: Specify rod code number based on diameter. Give thread style number for a standard thread or specify dimensions. See “Style 3 Rod End” below.

Cushions: If cushions are required specify according to the model number on the next page. If the cylinder is to have a double rod and only one cushion is required, be sure to specify clearly which end of the cylinder is to be cushioned.

Special Modifications: Additional information is required on orders for cylinders with special modifications. This is best handled with descriptive notes. For further information, consult factory.

Fluid Medium: Series 2A hydraulic cylinders are equipped with seals for use with lubricated air.

Class 1 Seals

Class 1 seals are the seals provided as standard in a cylinder assembly unless otherwise specified. For further information on fluid compatibility or operating limitations of all components, see section C.

For the 2A series cylinders the following make-up Class 1 Seals:
Primary Piston Rod Seal – Nitrile with PTFE back-up washers

Piston Rod Wiper – Nitrile

Piston Seals – Nitrile with polymyte back-up washers

O-Rings – Nitrile

Combination Mountings

Single Rod End The first mounting is the one called out on the head end of the cylinder. The second or subsequent mountings are called out as they appear in the assembly moving away from the rod end. Exception: When tie rod mountings are part of a combination, the model number should contain an “S” (Special) in the model code and a note in the body of the order clarifying the mounting arrangement. The “P” is used to define a thrust key and is not considered to be a mounting. However, it is located at the primary end.

Example: 4.00 CCBB2ALTS14AC x 10.000

Combination “C” mounting head only. “BB” mounting cap end
This cylinder is also cushioned at both ends.

Double Rod End In general, the model number is read left to right corresponding to the cylinder as viewed from left to right with the primary

end at rod end #1. See Double Rod Models information page in this section. For this option the piston rod number, piston rod end, and piston rod threads are to be specified for both ends. The simplest are for symmetric cylinders such as: TD, C and F mounts. All other mounting styles, the description of the first rod end will be at the mounting end. In the case of multiple mounts, the description of the first rod end will be at the primary mounting end. For “DD” mounts, the description of the first rod end will be the same location as the “XI” dimension.

Example: 4.00 KDD2ALT24A/18A x 10.000 XI=8

This is a center trunnion mounting cylinder with the XI dimension measured from the code 2 rod side of the cylinder which has the style 4 thread. The opposite end code 1 rod with the style 8 thread.

Style 3 Rod End

A style 3 rod end indicates a special rod end configuration. All special piston rod dimensions must have **all three**: KK; A; W/WF or LA/LAF specified with the rod fully retracted. A sketch or drawing should be submitted for rod ends requiring special machining such as snap ring grooves, keyways, tapers, multiple diameters, etc. It is good design practice to have this machining done on a diameter at least 0.065 inches smaller than the piston rod diameter. This allows the piston rod to have a chamfer preventing rod seal damage during assembly or

maintenance. Standard style 55 rod ends with a longer than standard WG dimension should call out a style 3 rod end and the note: **same as 55 except WG=_____**. A drawing should be submitted for special 55 rod ends that have specific tolerances or special radii. Special rod ends that have smaller than standard male threads, larger than standard female threads, or style 55 rod ends with smaller than standard AF or AE dimensions are to be reviewed by Engineering for proper strength at operating pressure.

Service Policy

On cylinders returned to the factory for repairs, it is standard policy for the Cylinder Division to make such part replacements as will put the cylinder in as good as new condition. Should the condition of the returned cylinder be such that expenses for repair would exceed the costs of a new one, you will be notified.

Address all correspondence and make shipments to, Service Department at your nearest regional plant listed in the pages of this catalog.

Certified Dimensions

Parker Cylinder Division guarantees that all cylinders ordered from this catalog will be built to dimensions shown. All dimensions are certified to be correct, and thus it is not necessary to request certified drawings.

Series 2A / 2AN Model Numbers – How to Develop Them – How to “Decode” Them

Parker Series 2A / 2AN cylinders can be completely and accurately described by a model number consisting of coded symbols. To

develop a model number, select only those symbols that represent the cylinder required, and place them in the sequence indicated below.

Feature	Description	Page No.	Symbol	
Bore*	Specify in inches	—	—	6" C K F P TB 2A L T V S 1 4 2 A C 12"
Cushion-Head	Used only if cushion required	52-53	C	↑
Double-Rod	Used only if double-rod cylinder is required	28	K	↑
Mounting* Style	Head Tie Rods Extended	4 & 16	TB	↑
	Cap Tie Rods Extended	4 & 16	TC	↑
	Both End Tie Rods Extended	4 & 16	TD	↑
	Head Rectangular Flange	4	J	↑
	Cap Rectangular Flange	4	H	↑
	Head Square Flange	6 & 16	JB	↑
	Cap Square Flange	6 & 16	HB	↑
	Side Lugs	8 & 18	C	↑
	Side Tapped	8 & 20	F	↑
	Cap Fixed Clevis	12 & 22	BB	↑
	Head Trunnion	10 & 24	D	↑
	Cap Trunnion	10 & 24	DB	↑
	Intermediate Fixed Trunnion ‡	10 & 24	DD	↑
	Spherical Bearing	26 & 27	SB	↑
Mounting Modifications	Thrust Key (Styles C and F only)	48	P	↑
	Manifold Port O-Ring Seal (Style C only)	47	M	↑
	Removable Trunnions	—	R	↑
Combination Mounting Style	Any Practical Mounting Style Listed Above	—	As listed above	↑
		—		↑
Series*	Used in all Model Numbers	—	2A	↑
		40 - 42	2AN	↑
Piston*	Lipseal™ Piston standard.	—	L	↑
	Piston Bumper Seals	—	4	↑
Ports*	NPTF (Dry Seal Pipe Thread) is standard. Used only for SAE Straight Thread O-Ring Port	46	U	↑
	Used only for BSP (Parallel Thread ISO 228)	46	T	↑
	Used only for BSPT (Taper Thread ISO 7-Rc)	46	B	↑
	Used only for Metric Thread	46	G	↑
	Used only for Metric Thread per ISO 6149	46	Y	↑
Common Modifications	Nut Retained Piston	3	F	↑
	Fluorocarbon Seals	45	V	↑
	Water Service	45	W	↑
Special Modifications	Used only if special Modifications are required:			↑
	Oversize Ports	47	S	Use Symbol S to designate any special modification except piston rod end.
	Port Position Change	46		
	Rod End Boots	56		
	Special Seals	45		
	Stop Tube†	49		
	Stroke Adjuster	48		
	Tie Rod Supports	48		
	Water Service Modification	45		
Piston Rod* Number	For Single Rod Cylinders, select one only. Refer to Rod number listing, Table 2, Pages 4 through 27. Note: Check chart on page 47 for minimum piston rod diameter	—	1	↑
		—	2	↑
		—	3	↑
		—	4	↑
		—	5	↑
		—	6	↑
		—	7	↑
		—	8	↑
		—	9	↑
		—	0	↑
Piston* Rod End	Select:			↑
	Style 4 Small Male	4	4	Styles 4, 8, and 9 are catalog standards. Specify Style 3 for any special piston rod end.
	Style 7 Female Thread for Spherical Rod Eye	27-28	7	
	Style 8 Intermediate Male	4	8	
	Style 9 Short Female	4	9	
	Style 55 Rod End for Flange Coupling	37	55	
Style 3 Special (Specify)	4	3		
Piston Rod Alternate Thread	Used only for stud two times longer than standard.	—	2	↑
Piston Rod* Threads	UNF Standard	—	A	↑
	Metric	—	M	↑
	No Thread	—	N	↑
Cushion-Cap	Used only if cushion required	52-53	C	↑
Stroke*†	Specify in inches	—	—	↑

Double Rod Cylinders
 For double rod cylinders, specify rod number and rod end symbols for both piston rods. A typical double rod model number would be:
 6" KJ-2AU14A/14AX12"

*Required for Basic Cylinder Model Number
 Dark Arrows Indicate Basic Minimum Model Number

‡Specify XI dimension
 †In case of Stop Tube, call out gross stroke length.

Cylinder serial numbers are factory production record numbers and are assigned to each cylinder, in addition to the model number.



Parker Non-Lube Heavy Duty Air Cylinders

Series 2AN

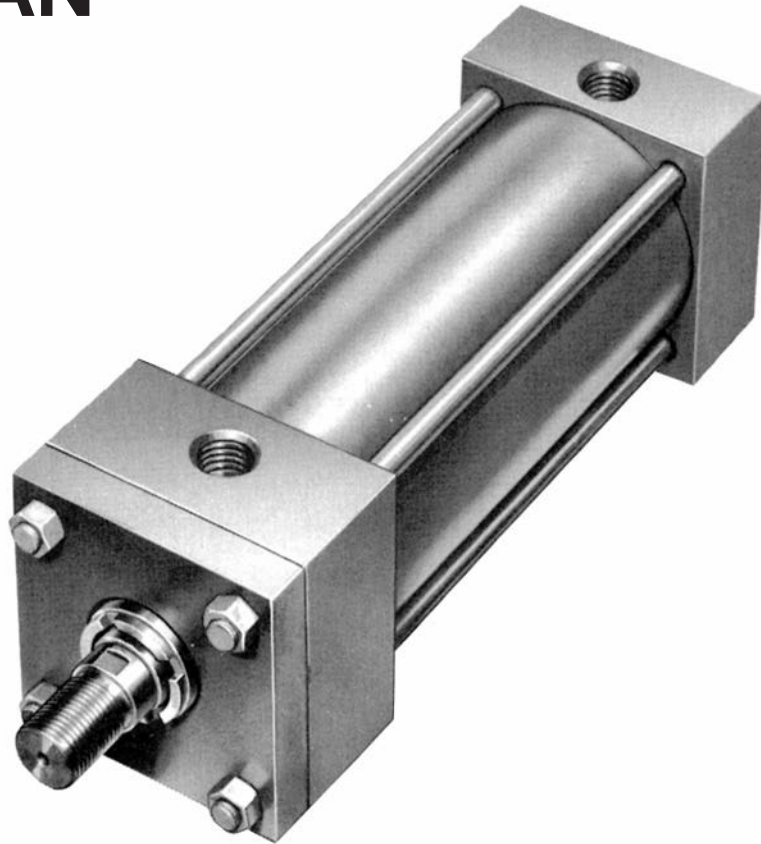

For millions of trouble free cycles

- Nominal Pressure – 250 PSI – Air Service
- Standard Bore Sizes 1" through 14"
- Piston Rod Diameters – 1/2" through 5 1/2"
- 14 Standard Mounting Styles
- NFPA Interchangeable
- Exceeds Automotive Specifications

Another Parker Cylinder Innovation...

The SERIES 2AN Non-Lube Air Cylinder with Proven Performance.

Over 21 million trouble free cycles with... **ZERO LEAKAGE.**

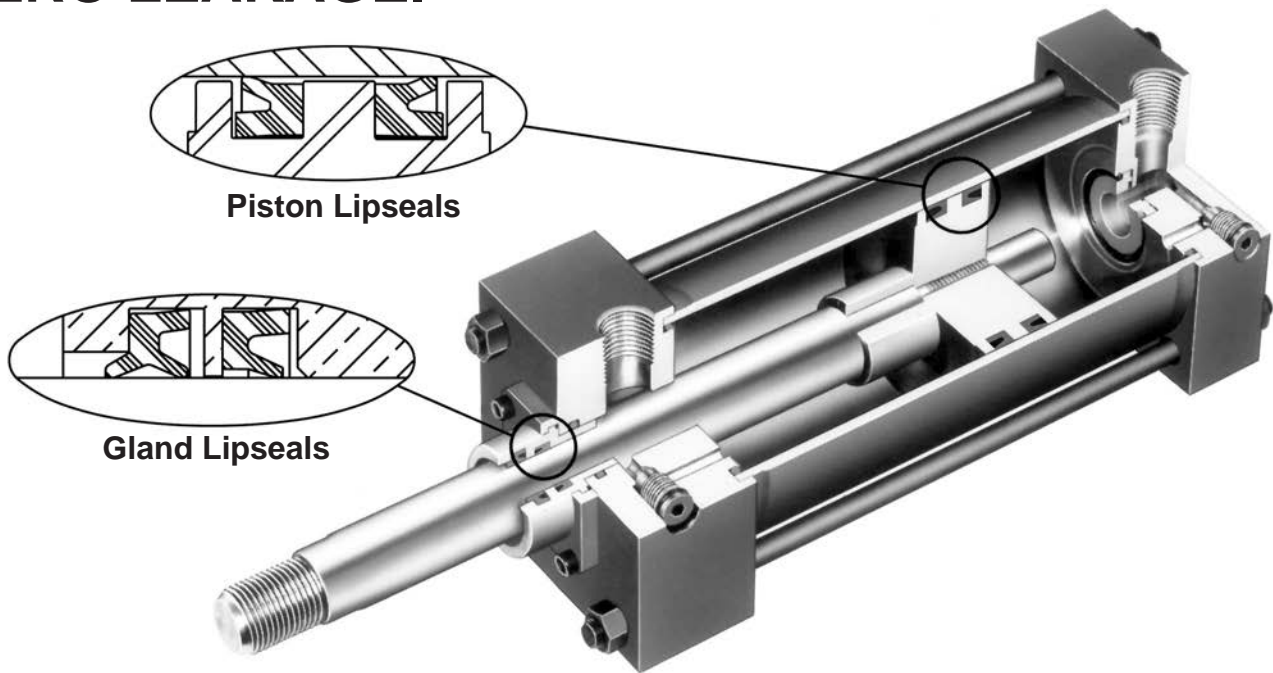

Design Data

In 1971 Parker experimented with the use of specially designed composite materials in the piston and gland of their cylinders. Their use of storing lubricating oil met with good results. Through extensive testing it was learned that the outside diameter of the material in the piston and the inside diameter on the material in the gland showed signs of wear and ultimately would lose contact with the surface of the cylinder body bore or piston rod. As a result, the cylinders lost their self lubricating capacity.

Today's industrial market demands more from a pneumatic cylinder. Cylinders are still required to handle tough, heavy-duty applications. But, more and more, these cylinders operate in environments or circumstances where it is not possible or advantageous to add lubrication to the compressed air entering the cylinder. Certain packaging and assembly operations, food environments, and microprocessor chip manufacturing are typical examples of areas where the exhausting of oil into the environment is not desirable. In many other situations, "non-lube" systems are used when proper air line lubrication is not present because of the time and expense of keeping lubricators filled and operating correctly.

Increased market demand and continuous research and testing efforts inspired the development of the Series 2AN Non-Lubricated Air Cylinder. In bore sizes to 14"

diameter and rod diameters to 5-1/2", the Parker Series 2AN air cylinder features rounded lip rod and piston seals. These seals glide over the PTFE based lubricant that is provided at the time of manufacture. The Parker Series 2AN Non Lubricated Air Cylinder maintains the lubricant film where it belongs; on the seals bearing surfaces, piston rod and cylinder bore.

Benefits include... long seal and bearing life. No oil needs to be added through the use of lubricators. As the cylinder strokes, no oil is expelled into the atmosphere with the exhaust air.

Anatomy of Series 2AN Sealing and Lubricant Retention Systems

Rounded sealing lip glides over lubricant film instead of scraping it off. Reduces friction, increases life and eliminates the need for added lubrication.

Increased heel thickness and outer lip extension improve stability, resist rolling.

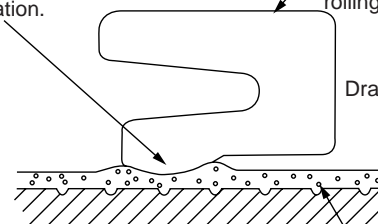

High integrity lubricant film with suspended PTFE particles

In the Series 2AN you get all the cost saving benefits and features of the popular heavy duty Series 2A air cylinder including...

- The Jewel Rod Gland Assembly for positive no leak sealing
 - Piston rod, hard chrome plated and case hardened steel
 - High strength rolled thread Piston Rod Stud
 - Steel tube cylinder body with chrome-plated micro finish bore...
- PLUS** the innovative "NON-LUBE" feature which further increases your benefits of lower operating and maintenance costs.

Standard Specifications

- Heavy Duty Service—ANSI/(NFPA) T3.6.7R3-2009 Specifications and Mounting Dimension Standards.
- Standard Construction—Square Head — Tie Rod Design.
- Standard Temperature— -10°F. to +165°F.
- Standard Fluid—Filtered Dry Air.
- Strokes—Available in any Practical Stroke Length.
- Cushions—Optional at either end or both ends of stroke. "Float Check" at cap end.

In line with our policy of continuing product improvement, specifications in this catalog are subject to change.

Available Bore and Rod Sizes*

Bore Sizes Available	1"	1 1/2"	2"	2 1/2"	3 1/4"	4"	5"	6"	8"	10"	12"	14"
-----------------------------	----	--------	----	--------	--------	----	----	----	----	-----	-----	-----

Rod Sizes Available	1/2"	5/8"	1"	1 3/8"	1 3/4"	2"	2 1/2"	3"	3 1/2"	4"	4 1/2"	5"	5 1/2"
----------------------------	------	------	----	--------	--------	----	--------	----	--------	----	--------	----	--------

*For specific cylinder bore size/piston rod availabilities and dimensions, see Series 2A Cylinder.

Notes

Theoretical Push and Pull Forces for Pneumatic and Hydraulic Cylinders

Push Force and Displacement

Cyl. Bore Size (Inches)	Piston Area (Sq. In.)	Cylinder Push Stroke Force In Pounds At Various Pressures						Cu. Ft. Free Air At 80 Lbs. Pressure, Required To Move Max. Load 1 Inch
		25	50	65	80	100	250	
1	.785	20	39	51	65	79	196	.00293
1 1/2	1.767	44	88	115	142	177	443	.00659
2	3.14	79	157	204	251	314	785	.01171
2 1/2	4.91	123	245	319	393	491	1228	.01830
3 1/4	8.30	208	415	540	664	830	2075	.03093
4	12.57	314	628	817	1006	1257	3143	.04685
5	19.64	491	982	1277	1571	1964	4910	.07320
6	28.27	707	1414	1838	2262	2827	7068	.10541
7	38.49	962	1924	2502	3079	3849	9623	.14347
8	50.27	1257	2513	3268	4022	5027	12568	.18740
10	78.54	1964	3927	5105	6283	7854	19635	.29280
12	113.10	2828	5655	7352	9048	11310	28275	.42164
14	153.94	3849	7697	10006	12315	15394	38485	.57389

Deductions for Pull Force and Displacement

Piston Rod Dia. (Inches)	Piston Area (Sq. In.)	Piston Rod Diameter Force In Pounds At Various Pressures						Cu. Ft. Free Air At 80 Lbs. Pressure, Required To Move Max. Load 1 Inch
		To determine Cylinder Pull Force or Displacement, deduct the following Force or Displacement corresponding to Rod Size, from selected Push Stroke Force or Displacement corresponding to Bore Size in table above.						
		25	50	65	80	100	250	
1/2	.196	5	10	13	16	20	49	.00073
5/8	.307	8	15	20	25	31	77	.00114
1	.785	20	39	51	65	79	196	.00293
1 3/8	1.49	37	75	97	119	149	373	.00554
1 3/4	2.41	60	121	157	193	241	603	.00897
2	3.14	79	157	204	251	314	785	.01171
2 1/2	4.91	123	245	319	393	491	1228	.01830
3	7.07	177	354	460	566	707	1767	.02635
3 1/2	9.62	241	481	625	770	962	2405	.03587
4	12.57	314	628	817	1006	1257	3143	.04685
4 1/2	15.90	398	795	1033	1272	1590	3975	.05929
5	19.64	491	982	1277	1571	1964	4910	.07320
5 1/2	23.76	594	1188	1544	1901	2376	5940	.08857

General Formula

The cylinder output forces are derived from the formula:

$$F = P \times A$$

Where F = Force in pounds.

P = Pressure at the cylinder in pounds per square inch, gauge.

A = Effective area of cylinder piston in square inches.

Free Air refers to normal atmospheric conditions of the air at sea level (14.7 psi). Use above cu. ft. free air required data to compute

CFM required from a compressor at 80 psi. Cu. ft. of free air required at other pressures can be calculated using formula below.

$$V_1 = \frac{(P^2 + 14.7) V^2}{14.7}$$

Where V¹ = Free air consumption per inch of stroke (cubic feet).

V² = Cubic feet displaced per inch of stroke.

P² = Gauge pressure required to move maximum load.

Operating Fluids and Temperature Range

Fluidpower cylinders are designed for use with pressurized air, hydraulic oil and fire resistant fluids, in some cases special seals are required.

Standard Seals (class 1)

Class 1 seals are what is normally provided in a cylinder unless otherwise specified. They are intended for use with fluids such as: air, nitrogen, mineral base hydraulic oil or MIL-H-5606 within the temperature range of -10°F (-23°C) to +165°F (+74°C). Generally they are nitrile except for piston rod seals in hydraulic cylinders. However the individual seals may be nitrile (Buna-N) enhanced polyurethane, polymyte, PTFE or filled PTFE

Water Base Fluid Seals (class 2)

Generally class 2 seals are intended for use with water base fluids within the temperature of -10°F (-23°C) to +165°F (+74°C) except for High Water Content Fluids (HWCF) in which case Class 6 seals should be used. Typical water base fluids are: Water, Water-Glycol, Water-in Emulsion, Houghto-Safe 27, 620, 5040, Mobil Pyrogard D, Shell Irus 905, Ucon Hydrolube J-4. These seals are nitrile. Lipseal will have polymyte or PTFE back-up washer when required. O-rings will have nitrile back-up washers when required.

Ethylene Propylene (EPR) Seals (class 3)

Class 3 seals are intended for use with some Phosphate Ester Fluids between the temperatures of -10°F (-23°C) to +130°F (+54°C). Typical fluids compatible with EPR seals are Skydrol 500 and 700. EPR are Ethylene Propylene. Lipseals will have a PTFE back-up washer when required. O-rings will have EPR back-up washers when required.

Note: EPR seals are not compatible with mineral base hydraulic oil or greases. Even limited exposure to these fluids will cause severe swelling. PTFE back-up washer may not be suitable when used in a radiation environment.

Low Temperature Nitrile Seals (class 4)

Class 4 seals are intended for low temperature service with the same type of fluids as used with Class 1 seals within the temperature range of -50°F (-46°C) to +150°F (+66°C). Lipseals will have leather, polymyte or PTFE back-up washers when required. O-rings will have nitrile back-up washers when required. **Note:** Certain fluids may react adversely with Class 4 seals compared to Class 1 seals.

Fluorocarbon Seals (class 5)

Class 5 seals are intended for elevated temperature service or for some Phosphate Ester Fluids such as Houghto-Safe 1010, 1055, 1120; Fyrquel 150, 220, 300, 350; Mobile Pyrogard 42, 43, 53, and 55. **Note:** In addition, class 5 seals can be used with fluids listed below under standard service. However, they are not compatible with Phosphate Ester Fluids such as Skydrols. Class 5 seals can operate with a temperature range of -10°F (-23°C) to +250°F (+121°C). Class 5 seals may be operated to +400°F (+204°C) with limited service life. For temperatures above +250°F (+121°C) the cylinder must be manufactured with non-studded piston rod and thread and a pinned piston to rod connection. Class 5 Lipseals will have PTFE back-up washers when required. O-rings will have fluorocarbon back-up when required.

HWCF Seals (class 6)

Class 6 seals are intended for High Water Content Fluids (HWCF) such as Houghton, Hydrolubric 120B and Sonsol Lubrizol within the temperature range of +40°F (+4°C) to +120°F (+49°C). Class 6 seals are special nitrile compound dynamic seals. Lipseals will have PTFE and/or polymyte back-up washers when required. O-rings will have nitrile back-up washers when required. Because of the viscosity of these fluids, cylinders specified with class 6 seals, will also be modified to have lip seal piston seals and straight cushions.

Energized PTFE Seals (class 8)

Class 8 seals consist of PTFE piston lipseals, rod seal and wiperseal. Piston seals have an internal stainless steel spring to energize both the static and dynamic sealing lips. They are intended for high temperature applications, to 400° F (204° C), where longer seal life and improved high temperature sealing performance is required. Minimum operating temperature is -15°F (-26°C). Body and gland o-ring seals will be fluorocarbon. Fluid resistance is comparable to Class 5. Cylinders incorporating Class 8 Seals will not have studded piston rods.

Warning ⚠

The piston rod stud and the piston rod to piston threaded connections are secured with an anaerobic adhesive which is temperature sensitive. Cylinders are assembled with anaerobic adhesive having a maximum temperature rating of +250°F (+121°C). Cylinders specified with all other seal compounds (built before 1997) were assembled with anaerobic adhesive having a maximum operating temperature rating +165°F (+74°C). These temperature limitations are necessary to prevent the possible loosening of the threaded connections. Cylinders

originally manufactured (before 1997) with class 1 seals (Nitrile) that will be exposed to ambient temperatures above +165°F (+74°C) must be modified for higher temperature service. Contact the factory immediately and arrange for the piston to rod and the stud to piston rod connections to be properly re-assembled to withstand the higher temperature service.

Hi-Load Seals

Hi-load seals consist of one or two filled PTFE dynamic piston seals with an elastomer expander underneath. Hi-load piston arrangement normally consists of a wear ring on each end of the piston with the seals in the middle. These types of seals are virtually leak free seals under static conditions and can tolerate high pressure. The wear rings on the piston can also tolerate high side loads. The dynamic portion of the seal is bronze filled PTFE and compatible with all conditions and fluids listed on this page. However, carbon filled PTFE will provide better seal life when used with class 6 fluids. A nitrile expander will be provided unless Class 3 or 5 seals are specified. In those cases the expander will be of EPR or fluorocarbon respectively. **Note:** It may be necessary to cycle the piston seals 40 or 50 times before achieving leakage free performance.

Lipseal Pistons

Under most conditions lipseals provide the best all around service for pneumatic applications. Lipseals with a back-up washer are often used for hydraulic applications when virtually zero static leakage is required. Lipseals will function properly in these applications when used in conjunction with moderate hydraulic pressures. A high load piston option is recommended when operating at high pressures and especially with large bore hydraulic cylinders.

Low Friction Hydraulic Seals

Low Friction hydraulic seals are available as an option for both piston and rod seals for Series 2H and 3H cylinders. They are sometimes used when a cylinder is controlled by servo or proportional valve. The seal assembly itself is a two piece assembly consisting of a filled PTFE dynamic seal with an elastomer expander. A piston seal assembly consists of one seal assembly in the middle of the piston with a filled PTFE wear ring on each side of the piston. The piston rod seal assembly consists of two seal assemblies and an elastomer wiper seal. The filled PTFE seals are compatible with the fluids listed on this page and provide virtually leak free sealing. The expanders and rod wiper will be fluorocarbon unless EPR or fluorocarbon seals are specified. In those cases the expanders and wiper will be EPR and fluorocarbon respectively. When specifying low friction seals specify if piston, piston rod seals or both are required. **Note:** It may be necessary to cycle these seals 40 or 50 times before achieving leakage free performance.

Cast Iron Piston Rings

Cast iron rings are the standard piston seals for Series 2H cylinders. They offer the widest operating conditions by tolerating high operating pressures, wide temperature range and are compatible with most fluids. The only drawback of cast iron rings is that they allow a small amount of leakage. The leakage for a 4" bore cylinder, operating at 2000 psi, with mineral base hydraulic fluid will be less than 10in³/min. Leakage will increase as pressure, bore size and viscosity of the operating hydraulic fluid increases. For these reasons cast iron rings are not recommended when using water or (HWCF) fluids.

Water Service

Series 2A cylinders can be modified to make them more suitable for use with water as the operating medium. The modifications include chrome-plated cylinder bore; electroless nickel-plated head, cap and piston; chrome-plated 17-4 stainless steel piston rod; chrome plated cushion sleeve or cushion spear.

Series 2A cylinders can also be modified for water operation and supplied with chrome-plated cylinder bore; electroless nickel-plated head, cap and piston; chrome-plated precipitation hardened stainless steel piston rod, chrome-plated cushion sleeve or cushion spear.

Warranty

Parker Hannifin will warrant cylinders modified for water or high water content fluid service to be free of defects in materials or workmanship, but cannot accept responsibility to premature failure due to excessive wear due to lack of lubricity or where failure is caused by corrosion, electrolysis or mineral deposits within the cylinder.

Ports

Ports

Parker hydraulic and pneumatic cylinders can be supplied with S.A.E. straight O-ring ports or N.P.T.F. pipe thread ports. For the type of port recommended and port size, see respective product catalogs. If specified on your order, extra ports can be provided on the sides of heads or caps that are not occupied by mountings or cushion valve.

Standard port location is position 1 as shown on line drawings in product catalog and Figure 1 below. Cushion adjustment needle and check valves are at positions 2 and 4 (or 3), depending on mounting style. Heads or caps which do not have an integral mounting can be rotated and assembled with ports at 90° or 180° from standard position. Mounting styles on which head or cap can be rotated at no extra charge are shown in Table A below. To order, specify by position number. In such assemblies the cushion adjustment needle and check valve rotate accordingly, since their relationship with port position does not change.

Figure 1

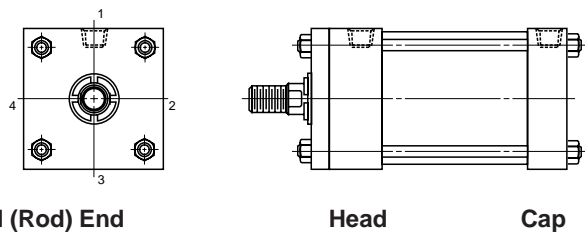

Head (Rod) End

Head

Cap

Table A

Mounting Style	Port Position Available	
	Head End	Cap End
T, TB, TC, TD, H, HB, J, JB, DD	1, 2, 3 or 4	1, 2, 3 or 4
BB, DB	1,2, 3 or 4	1 or 3
D	1 or 3	1, 2, 3 or 4
C, F	1	1

Cylinder Port Options

- Option "T" SAE Straight Thread O-Ring Port. Recommended for most hydraulic applications.
- Option "U" Conventional NPTF Ports (Dry-Seal Pipe Threads). Recommended for pneumatic applications only.
- Option "R" BSPP Port (British Parallel Thread). ISO 228 port commonly used in Europe.
- Option "B" BSPT (British Tapered Thread).
- Option "G" Metric Straight Thread Port similar to Option "R" with metric thread. Popular in some European applications.
- Option "Y" ISO-6149-1 Metric Straight Thread Port. Recommended for all hydraulic applications designed per ISO standards.

Ports can be supplied at positions other than those shown in Table A at an extra charge. To order, specify port position as shown in Figure 1.

Available Ports for Series 2A Cylinders

Bore	"T" SAE Standard	"U" NPTF Pipe Thread	"R" BSPP Parallel Thread	"B" BSPT Taper Thread	"G" Metric Straight Thread	"Y" ISO-6149-1 Metric Straight Thread
1	#6	1/4	1/4	1/4	M14 x 1.5	M14x 1.5 ¹
1 1/2	#6	3/8	3/8 ²	3/8	M14 x 1.5	M14 x 1.5 ¹
2	#6	3/8	3/8	3/8	M14 x 1.5	M14 x 1.5
2 1/2	#6	3/8	3/8	3/8	M14 x 1.5	M14 x 1.5
3 1/4	#10	1/2	1/2	1/2	M22 x 1.5	M22 x 1.5
4	#10	1/2	1/2	1/2	M22 x 1.5	M22 x 1.5
5	#10	1/2	1/2	1/2	M22 x 1.5	M22 x 1.5
6	#12	3/4	1/2	1/2	M26 x 1.5	M27 x 2
8	#12	3/4	3/4	3/4	M26 x 1.5	M27 x 2

¹ Not available on code 2 rods

² BSPP fitting thread length must not exceed 0.390" in head port for 1.50" bore with code 2 rod.

Oversize Ports

Oversize NPTF or SAE straight thread ports can be provided. For ports one size larger than standard, welded port bosses which protrude from the side of the head or cap are supplied. For dimensions, see drawing and table below.

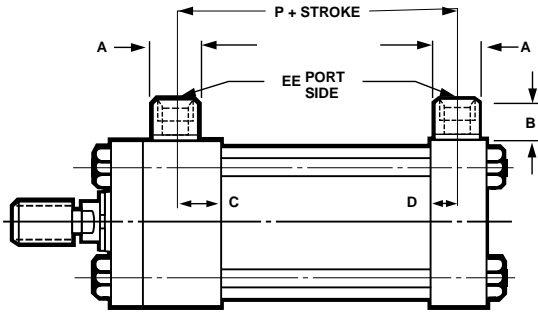

**Oversize NPTF Port Boss Dimensions
Series 2A Cylinders**

Bore	EE (NPTF)	A (Dia.)	B	C	D	P
1	3/8	7/8	3/4	9/16	1/2	2 1/16
1 1/2	1/2	1 1/8	15/16	9/16	1/2	2 3/16
2	1/2	1 1/8	15/16	9/16	1/2	2 3/16
2 1/2	1/2	1 1/8	15/16	9/16	1/2	2 5/16
3 1/4	3/4	1 3/8	1	11/16	5/8	2 9/16
4	3/4	1 3/8	1	11/16	5/8	2 9/16
5	3/4	1 3/8	1	11/16	5/8	2 13/16
6	1	1 3/4	1 3/16	15/16	3/4	3 3/16
7-8	1	1 3/4	1 3/16	15/16	3/4	3 5/16
10	1 1/4	2 1/4	1 5/16	1 1/8	1	4 1/4
12	1 1/4	2 1/4	1 5/16	1 1/8	1	4 3/4
14	1 1/2	2 1/2	1 9/16	1 1/4	1 1/8	5 1/2

Manifold Ports

Side mounted cylinders, Style C can be furnished with the cylinder ports arranged for mounting and sealing to a manifold surface. The ports are drilled and counterbored for O-ring seals which are provided. With these specifications, the mounting is designated Style CM or KCM.

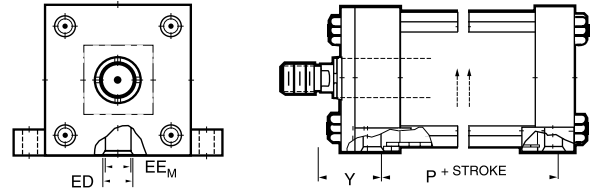

Dimensions —

**Manifold Ports for Single and Double Rod Cylinders
Series 2A Cylinders**

Bore	Rod Code	Rod. Dia. (MM)	Y+1/32	P+1/32	EE_M	ED
1	All	All	1 15/16	2 1/8	3/8	1 11/16
1 1/2	1	5/8	2	2 1/8	1/2	1 3/16
	2	1	2 3/8			
2	1	5/8	2	2 1/8	1/2	1 3/16
	2	1 3/8	2 5/8			
	3	1	2 3/8			
2 1/2	1	5/8	2	2 1/4	1/2	1 3/16
	2	1 3/4	2 7/8			
	3	1	2 3/8			
	4	1 3/8	2 5/8			
3 1/4	1	1	2 7/16	2 5/8	5/8	1 5/16
	2	2	3 1/16			
	3	1 3/8	2 11/16			
	4	1 3/4	2 15/16			
4	1	1	2 7/16	2 5/8	5/8	1 5/16
	2	2 1/2	3 5/16			
	3	1 3/8	2 11/16			
	4	1 3/4	2 15/16			
	5	2	3 1/16			
5	1	1	2 7/16	2 7/8	5/8	1 5/16
	2, 6 & 7	3 1/2, 2 1/2 & 3	3 5/16			
	3	1 3/8	2 11/16			
	4	1 3/4	2 15/16			
	5	2	3 1/16			
6	1	1 3/8	2 13/16	3 1/8	7/8	1 3/16
	2, 5, 6, 7	4, 2 1/2, 3 & 3 1/2	3 7/16			
	3	1 3/4	3 1/16			
	4	2	3 3/16			
7 - 8	1	1 3/8	2 13/16	3 1/4	7/8	1 3/16
	2, 5, 6, 7, 8, 9 & 0	5 1/2, 2 1/2, 3, 3 1/2, 4, 4 1/2 & 5	3 7/16			
	3	1 3/4	3 1/16			
	4	2	3 3/16			
10	1	1 3/4	3 1/8	4 1/8	1 3/16	1 1/2
	3	2	3 1/4			
	4, 5, 6, 7, 8, 9 & 0	2 1/2, 3, 3 1/2, 4, 4 1/2, 5 & 5 1/2	3 1/2			
12	1	2	3 1/4	4 5/8	1 3/16	1 1/2
	3, 4, 5, 6, 7, 8 & 9	2 1/2, 3, 3 1/2, 4, 4 1/2, 5 & 5 1/2	3 1/2			
14	All	All	3 13/16	5 1/2	1 9/16	1 7/8

Stroke Data

Parker cylinders are available in any practical stroke length. The following information should prove helpful to you in selecting the proper stroke for your cylinder application.

Stroke Tolerances – Stroke length tolerances are required due to build-up of tolerances of piston, head, cap and cylinder body. Standard production stroke tolerances run +1/32" to -1/64" up to 20" stroke, +1/32" to -.020" for 21" to 60" stroke and +1/32" to -1/32" for greater than 60" stroke. For closer tolerances on stroke length, it is necessary to specify the required tolerance plus the operating pressure and temperature at which the cylinder will operate. Stroke tolerances smaller than .015" are not generally practical due to elasticity of cylinders.

If machine design requires such close tolerances, use of a stroke adjuster (below) may achieve the desired result.

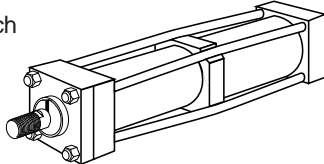

Tie Rod Supports

Rigidity of Envelope – The pre-stressed tie rod construction of Parker cylinders has advantages in rigidity within the limits of the cylinder tube to resist buckling. For long stroke cylinders within practical limits. Parker provides exclusive TIE ROD SUPPORTS (see table below) which move the tie rod centerlines radially outward.

Standard tie rod supports are kept within the envelope dimensions of the head and cap, and generally do not interfere with mounting a long cylinder.

Number of Supports Required	Stroke (Inches)													
	Bore	36	48	60	72	84	96	108	120	132	144	156	168	
1	—	1	1	1	2	Consult Factory								
1 1/2	—	—	1	1	1	2	2	2	3	3	3	4		
2	—	—	—	1	1	1	1	2	2	2	2	3		
2 1/2	—	—	—	—	—	1	1	1	1	1	2	2		
3 1/4	—	—	—	—	—	—	—	1	1	1	1	1		
4	—	—	—	—	—	—	—	—	—	1	1	1		

Note: 5" through 14" bore sizes — no supports required.

Stroke Adjusters

Stroke Adjusters – For the requirement where adjusting the stroke is specified. Parker has several designs to offer, one of which is illustrated below. This is suitable for infrequent adjustment and is economical.*

Bore Size	D	J	K	L (Max.)
Series 2A				
1 1/2, 2	1/2 - 20	3/16	15/16	5
2 1/2, 3 1/4, 4	3/4 - 16	7/16	1 1/4	8
5, 6	1 - 14	5/8	1 11/16	9
8	1 1/2 - 12	15/16	2 1/8	18
10	2 - 12	1 5/16	2 11/16	20
12, 14	2 1/2 - 12	1 11/16	3 1/8	20
—	3 - 12	2	3 1/4	20
—	3 1/2 - 12	2 5/8	3 1/2	20

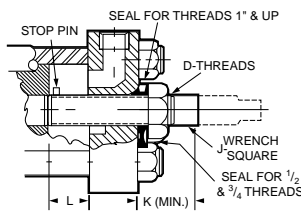

Here a "retracting stroke adjuster" must be called for in specifications, and the length of the adjustment must be specified.

Where frequent adjustment or cushions at the cap end are required, other designs are available according to application needs.

*Infrequent is defined by positioning the retract stroke in a couple of attempts at original machine set up. The frequent stroke adjuster is recommended for adjustments required after the original equipment has been adjusted by the original machine manufacturer.

Thrust Key Mountings

Thrust key mountings eliminate the need of using fitted bolts or external keys on side mounted cylinders. Parker cylinders in mounting styles CP and FP can be provided with the gland retainer plate extended below the mounting side of the cylinder (see illustration below). This extended retainer plate can then be fitted into a keyway milled into the mounting surface of the machine member. This is referred to as the "P" Modification of any side mounting style.

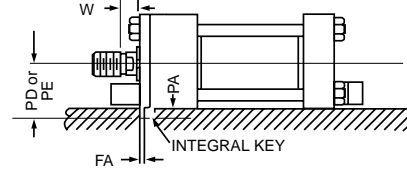

Series 2A

Bore	Dim. FA	Dim. PA	Dim. PD Mtg. Styles CP & FP
1	.312 +.000 -.002	3/16	15/16
1 1/2			1 3/16
2			1 7/16
2 1/2			1 11/16
3 1/4	.562 +.000 -.002	5/16	2 3/16
4			2 9/16
5			3 1/16
6	.687 +.000 -.002	3/8	3 5/8

Stop Tubing

Stop tube is recommended to lengthen the distance between the gland and piston to reduce bearing loads when the cylinder is fully extended. This is especially true of horizontally mounted and long stroke cylinders. Long stroke cylinders achieve additional stability through the use of a stop tube.

When specifying cylinders with long stroke and stop tube, be sure to call out the net stroke and the length of the stop tube. Machine design can be continued without delay by laying in a cylinder equivalent in length to the NET STROKE PLUS STOP TUBE LENGTH, which is referred to as GROSS STROKE.

Refer to piston rod/stroke selection chart to determine stop tube length.

Drawing A

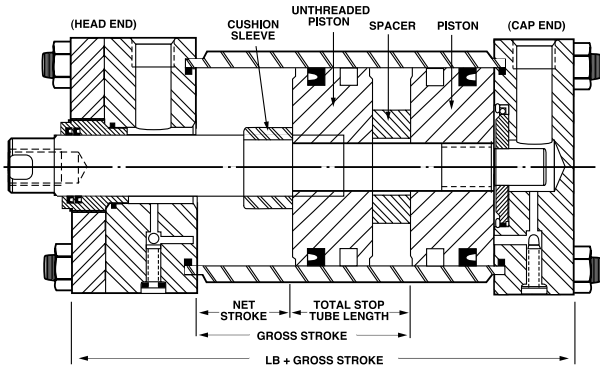

Double piston design is supplied on air cylinders with cushion head end or both ends.

Drawing B

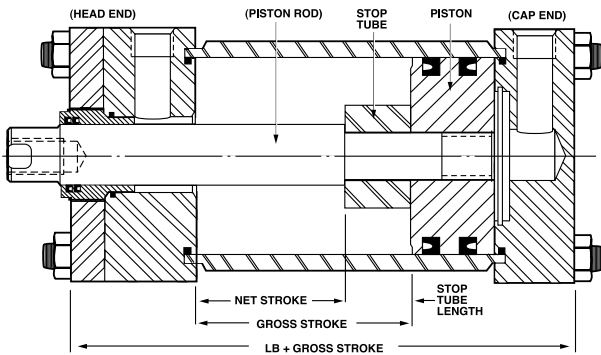

This design is supplied on all non cushion cylinders.

Mounting Classes

Standard mountings for fluid power cylinders fall into three basic groups. The groups can be summarized as follows:
Group 1 – Straight Line Force Transfer with fixed mounts which absorb force on cylinder centerline.

Group 2 – Pivot Force Transfer. Pivot mountings permit a cylinder to change its alignment in one plane.

Group 3 – Straight Line Force Transfer with fixed mounts which do not absorb force on cylinder centerline.

Because a cylinder's mounting directly affects the maximum pressure at which the cylinder can be used, the chart below should be helpful in selection of the proper mounting combination for your application. Stroke length, piston rod connection to load, extra piston rod length over standard, etc., should be considered for thrust loads. Alloy steel mounting bolts are recommended for all mounting styles, and thrust keys are recommended for Group 3.

Group 1 FIXED MOUNTS which absorb force on cylinder centerline.	
Heavy-Duty Service For Thrust Loads For Tension Loads	Mtg. Styles HB, TC Mtg. Styles JB, TB
Medium-Duty Service For Thrust Loads For Tension Loads	Mtg. Styles H, HB Mtg. Styles J, JB
Light-Duty Service For Thrust Loads For Tension Loads	Mtg. Style J Mtg. Style H
Group 2 PIVOT MOUNTS which absorb force on cylinder centerline.	
Heavy-Duty Service For Thrust Loads For Tension Loads	Mtg. Styles DD, D Mtg. Styles BB, DD, D, DB
Medium-Duty Service For Thrust Loads For Tension Loads	Mtg. Style BB Mtg. Style BB
Light-Duty Service For Thrust Loads For Tension Loads	_____
Group 3 FIXED MOUNTS which do not absorb force on the centerline.	
Heavy-Duty Service For Thrust Loads For Tension Loads	Mtg. Style C, CP Mtg. Style C, CP
Medium-Duty Service For Thrust Loads For Tension Loads	Mtg. Style F, FP Mtg. Style F, FP

Piston Rod — Stroke Selection Chart

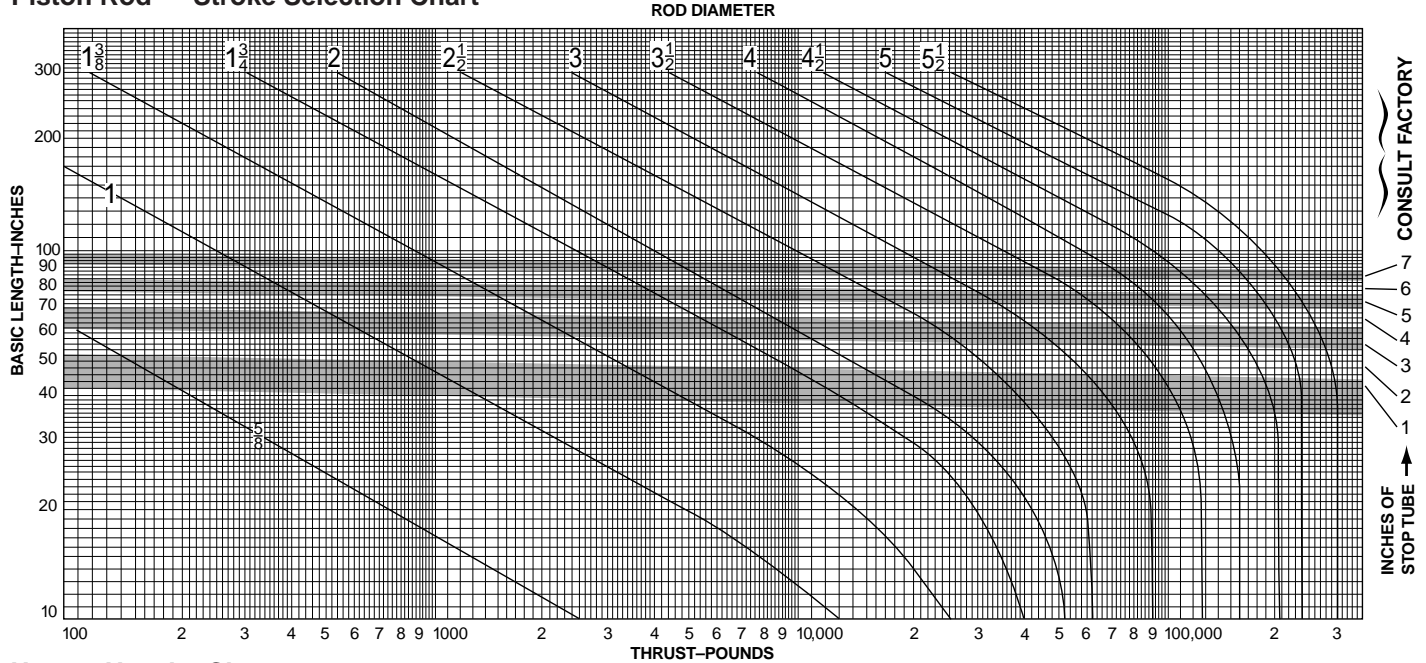

How to Use the Chart

The selection of a piston rod for thrust (push) conditions requires the following steps:

- Determine the type of cylinder mounting style and rod end connection to be used. Then consult the chart below and find the "stroke factor" that corresponds to the conditions used.
- Using this stroke factor, determine the "basic length" from the equation:

$$\text{Basic Length} = \frac{\text{Actual Stroke}}{\text{Stroke Factor}} \times \text{Stroke Factor}$$

The graph is prepared for standard rod extensions beyond the face of the gland retainers. For rod extensions greater than standard, add the increase to the stroke in arriving at the "basic length."

- Find the load imposed for the thrust application by multiplying the full bore area of the cylinder by the system pressure.
- Enter the graph along the values of "basic length" and "thrust" as found above and note the point of intersection:

- The correct piston rod size is read from the diagonally curved line labeled "Rod Diameter" next above the point of intersection.
- The required length of stop tube is read from the right of the graph by following the shaded band in which the point of intersection lies.

C) If required length of stop tube is in the region labeled "consult factory," submit the following information for an individual analysis:

- Cylinder mounting style.
- Rod end connection and method of guiding load.
- Bore, required stroke, length of rod extension (Dim. "LA") if greater than standard, and series of cylinder used.
- Mounting position of cylinder. (Note: If at an angle or vertical, specify direction of piston rod.)
- Operating pressure of cylinder if limited to less than standard pressure for cylinder selected.

Warning ⚠

Piston rods are not normally designed to absorb bending moments or loads which are perpendicular to the axis of piston rod motion. These additional loads can cause the piston rod end to fail. If these types of additional loads are expected to be imposed on the piston rods, their magnitude should be made known to our Engineering Department so they may be properly addressed. Additionally, cylinder users should always make sure that the piston rod is securely attached to the machine member.

Recommended Mounting Styles for Maximum Stroke and Thrust Loads	Rod End Connection	Case	Stroke Factor
Groups 1 or 3 Long stroke cylinders for thrust loads should be mounted using a heavy-duty mounting style at one end, firmly fixed and aligned to take the principal force. Additional mounting should be specified at the opposite end, which should be used for alignment and support. An intermediate support may also be desirable for long stroke cylinders mounted horizontally. See catalog page No. 80 under "Tie Rod Supports — Rigidity of Envelope" for a guide. Machine mounting pads can be adjustable for support mountings to achieve proper alignment.	Fixed and Rigidly Guided	I	.50
	Pivoted and Rigidly Guided	II	.70
	Supported but not Rigidly Guided	III	2.00
Group 2 Style D — Trunnion on Head	Pivoted and Rigidly Guided	IV	1.00
Style DD — Intermediate Trunnion	Pivoted and Rigidly Guided	V	1.50
Style DB — Trunnion on Cap or Style BB — Clevis on Cap	Pivoted and Rigidly Guided	VI	2.00

Acceleration and Deceleration Force Determination

The uniform acceleration force factor chart and the accompanying formula can be used to rapidly determine the forces required to accelerate and decelerate a cylinder load. To determine these forces, the following factors must be known: total weight to be moved, maximum piston speed, distance available to start or

stop the weight (load), direction of movement, i.e. horizontal or vertical, and load friction. By use of the known factors and the "g" factor from chart, the force necessary to accelerate or decelerate a cylinder load may be found by solving the formula (as shown in chart below) application to a given set of conditions.

Nomenclature

- V = Velocity in feet per minute
- S = Distance in inches
- F = Force in lbs.
- W = Weight of load in pounds
- g = Force factor
- f = Friction of load on machine ways in pounds

To determine the force factor "g" from the chart, locate the intersection of the maximum piston velocity line and the line representing the available distance. Project downward to locate "g" on the horizontal axis. To calculate the "g" factor for distances and velocities exceeding those shown on the chart, the following formula can be used:

$$g = v^2/s \times .0000517$$

Example: Horizontal motion of a free moving 6,000 lb load is required with a distance of 1/2" to a maximum speed of 120 feet per minute.

Formula (1) $F = Wg$ should be used.

$$F = 6,000 \text{ pounds} \times 1.50 \text{ (from chart)} = 9,000 \text{ pounds}$$

Assuming a maximum available pump pressure of 1,000 psi, a 4" bore cylinder should be selected, operating on push stroke at approximately 750 psi pressure at the cylinder to allow for pressure losses from the pump to the cylinder.

Assume the same load to be sliding on ways with a coefficient of friction of 0.15. The resultant friction load would be $6,000 \times 0.15 = 900$ lbs.

Formula (2) $F = Wg + f$ should be used.

$$F = 6,000 \text{ pounds} \times 1.5 \text{ (from chart)} + 900 = 9,900 \text{ lb}$$

Again allowing 750 psi pressure at the cylinder, a 5" bore cylinder is indicated.

Example: Horizontal deceleration of a 5000 pound load is required by using a 1" long cushion in a 5" bore cylinder having a 1 3/4" diameter piston rod. Cylinder bore area (19.64 Sq. In.) minus the rod area results in a minor area of 17.23 Sq. In. at head end of cylinder. A pump delivering 500 psi at the cylinder is used to push the load at 120 feet per minute. Friction coefficient is 0.15 or 750 lb.

In this example, the total deceleration force is the sum of the force needed to decelerate the 5,000 pounds load, and the force required to counteract the thrust produced by the pump.

- W = Load in lb = 5000
- S = Deceleration distance in inches = 1"
- V = Maximum piston speed in feet per minute = 120
- g = .74 (from chart)
- f = 750 pounds

Use formula (3) $F = Wg - f$

$$(F = Wg - f) = (5000 \times .74 - 750) = 2,950 \text{ Pounds}$$

The pump is delivering 500 psi acting on the 19.64 Sq. In. piston area producing a force (F2) of 9820 pounds. This force must be included in our calculations. Thus $F + F2 = 2950 + 9820 = 12,770$ pounds total force to be decelerated.

The total deceleration force is developed by the fluid trapped between the piston and the head. The fluid pressure is equal to the force (12,770 pounds) divided by the minor area (17.23 Sq. In.) equals 741 psi. This pressure should not exceed the non-shock rating of the cylinder.

Cushioning practice is to select a "g" factor between .2 and 1.5.

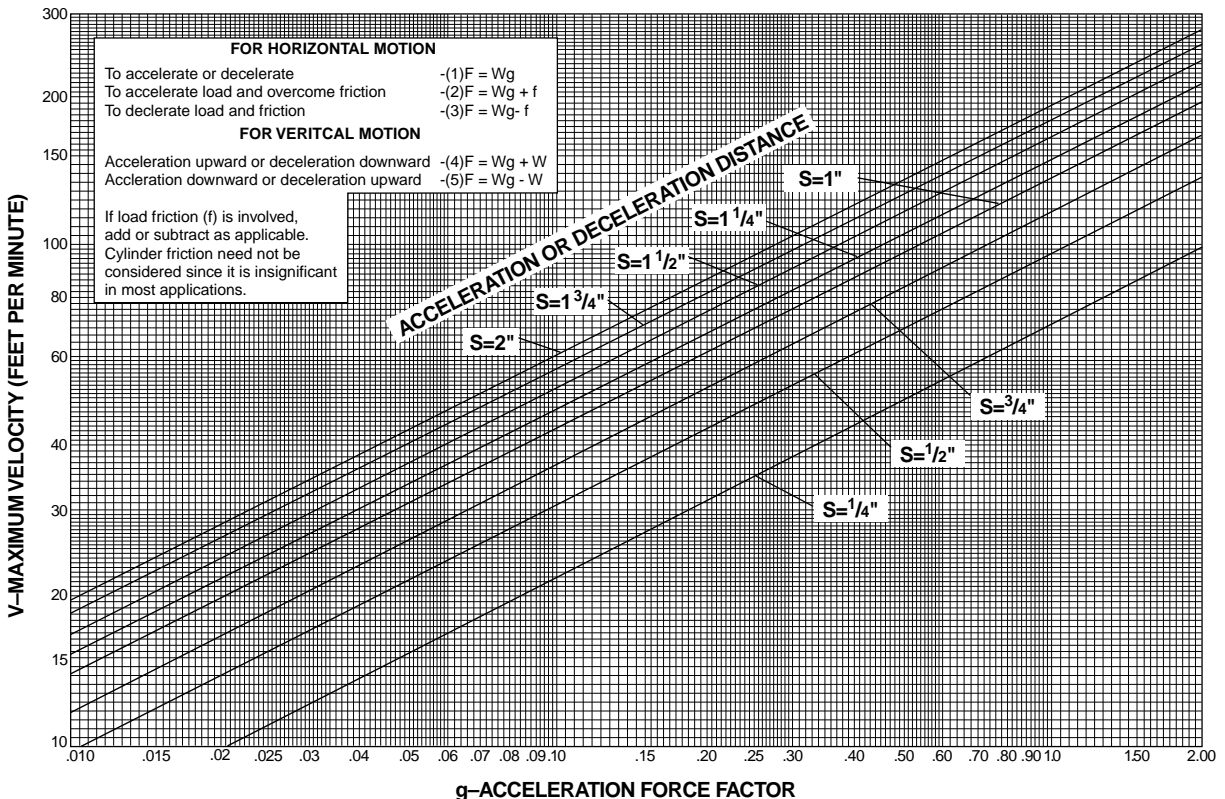

Cushion ratings for **Air Cylinders Only** are described in **table b-7** and **graph b-3**. To determine whether a cylinder will adequately stop a load without damage to the cylinder, the weight of the load (including the weight of the piston and the piston rod from **table b-6**) and the maximum speed of the piston rod must first be determined. Once these two factors are known, the **Kinetic Energy Graph** may be used. Enter the graph at its base for the value of weight determined, and project vertically to the required speed value. The point of intersection of these two lines will be the cushion rating number required for the application.

To determine the total load to be moved, the weight of the piston and rod must be included.

Total Weight = weight of the piston and non-stroke rod length (column 1) + weight of the rod per inch of stroke x the inches of stroke (Column 2) + the load to be move.

Weight Table

Bore Dia.	Column 1 Basic Wgt. (lb) for Piston & Non-Stroke Rod	Rod Dia.	Column 2 Basic Wgt. (lb) for 1" Stroke
1 1/2	1.5	5/8	.087
2	3.0	1	.223
2 1/2	5.4	1 3/8	.421
3 1/4	8.3	1 3/4	.682
4	14.2	2	.89
5	29.0	2 1/2	1.39
6	41.0	3	2.0
8	89.0	3 1/2	2.73
10	115.0	4	3.56
12	161.0	5	5.56
14	207.0	5 1/2	6.73

Table b-6

Example: a 3 1/4" bore cylinder, having a 1" diameter rod and 25" stroke; load to be moved is 85 pounds. Total load to be moved is then 8.3 lb + .223 lb/in. x 25 in. + 85 lb or a total of 99 lb.

Kinetic Energy Graph – Air Cylinders

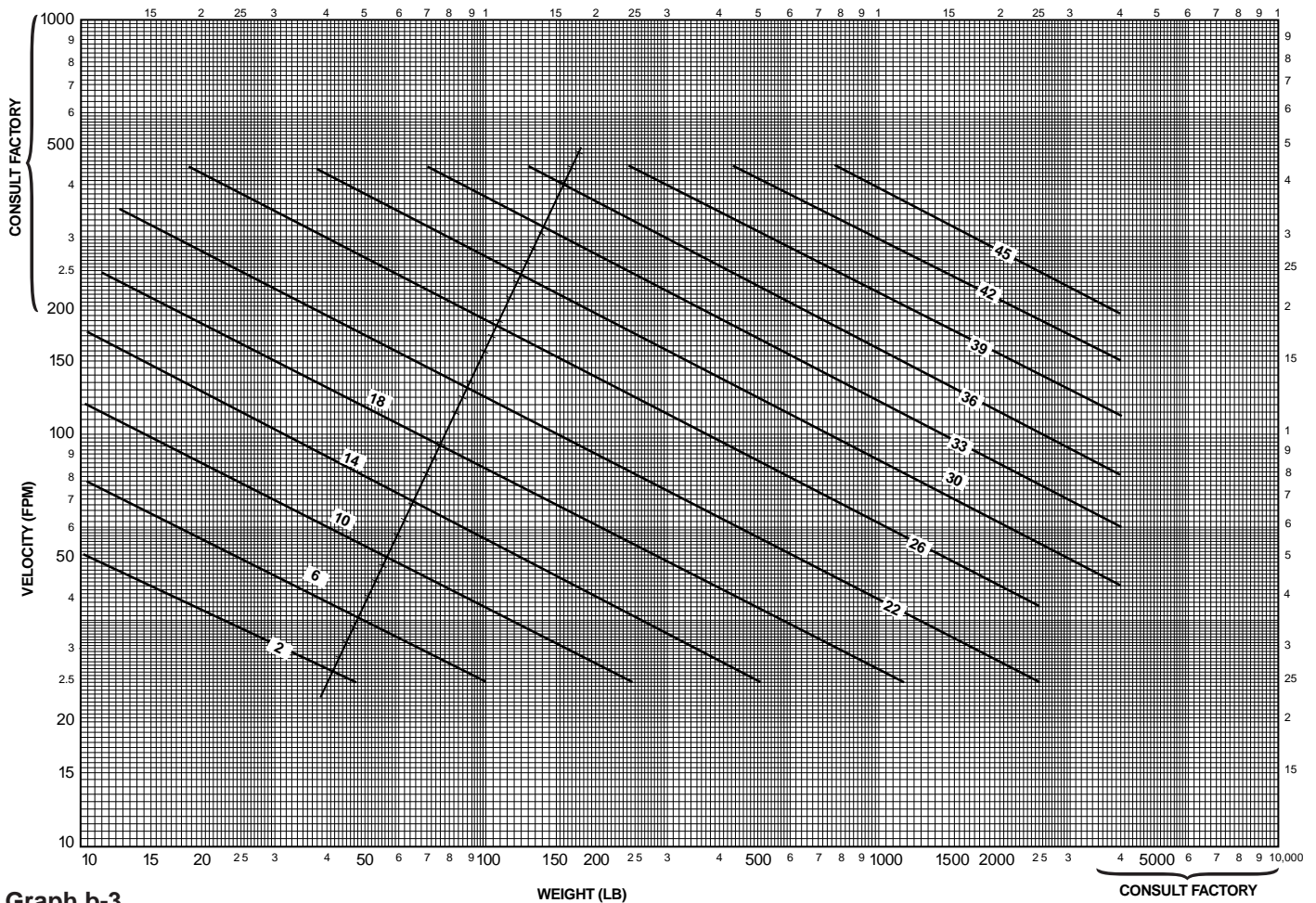

Graph b-3

Air Cylinder Cushion Ratings / Air Requirements

Now refer to **table b-7** and find the cushion ratings, using bore size and rod diameter of the cylinder selected. If a simple circuit is used, with no meter out or speed control, use the “no back pressure, Column A” values. If a meter out or speed control is to be used, use the back pressure column values. If the cushion rating found in **table b-7**, **below**, is **greater** than the number determined in **graph**

b-3, then the cylinder will stop the load adequately. If the cushion rating in **table b-7** is **smaller** than the number found in **graph b-3**, then a larger bore cylinder should be used. In those applications where back pressures exist in the exhaust lines, it is possible to exceed the cushion ratings shown in **table b-7**. In these cases, consult the factory and advise the amount of back pressure.

Air Cylinder Cushion Ratings Table

Bore Dia.	Rod Dia.	Rating With No Back Pressure	Rating With Back Pressure	Bore Dia.	Rod Dia.	Rating With No Back Pressure	Rating With Back Pressure
1 1/2	Cap End	12	17	7	3	24	30
	5/8	8	14		3 1/2	24	30
	1	3	8		4	23	29
2	Cap End	14	20		4 1/2	22	28
	5/8	12	18		5	21	27
	1	9	15		Cap End	29	35
	1 3/8	6	11		1 3/8	29	35
2 1/2	Cap End	17	23		1 3/4	29	34
	5/8	14	20		2	27	33
	1	14	19		2 1/2	26	32
	1 3/8	12	18	3	26	32	
	1 3/4	8	13	3 1/2	26	32	
3 1/4	Cap End	21	26	4	25	31	
	1	18	24	5	23	29	
	1 3/8	17	23	5 1/2	22	28	
	1 3/4	16	22	Cap End	33	39	
	2	13	19	1 3/4	32	38	
4	Cap End	23	28	2	31	37	
	1	20	27	2 1/2	31	36	
	1 3/8	20	26	3	30	36	
	1 3/4	19	25	3 1/2	30	36	
	2	17	23	4	30	36	
	2 1/2	17	22	5	28	34	
5	Cap End	26	31	5 1/2	27	33	
	1	23	28	Cap End	35	41	
	1 3/8	23	28	2	33	39	
	1 3/4	22	28	2 1/2	33	38	
	2	20	26	3	33	38	
	2 1/2	19	25	3 1/2	32	38	
	3	18	24	4	32	38	
6	3 1/2	15	20	5	31	36	
	Cap End	26	31	5 1/2	31	36	
	1 3/8	26	31	Cap End	38	43	
	1 3/4	26	31	2 1/2	37	42	
	2	24	29	3	36	42	
	2 1/2	24	29	3 1/2	36	41	
	3	22	28	4	36	41	
	3 1/2	21	27	5	35	40	
7	4	20	26	5 1/2	34	40	
	Cap End	28	33				
	1 3/8	28	33				
	1 3/4	28	33				
	2	26	31				

Table b-7

Air Requirement Per Inch of Cylinder Stroke

The amount of air required to operate a cylinder is determined from the volume of the cylinder and its cycle in strokes per minute. This may be determined by use of the following formulae which apply to a single-acting cylinder.

$$V = \frac{3.1416 L D^2}{4} \quad C = \frac{fV}{1728}$$

Where: V = Cylinder volume, cu. in.
L = Cylinder stroke length, in.
D = Internal diameter of cylinder in.
C = Air required, cfm
f = Number of strokes per minute

The air requirements for a double-acting cylinder is almost double that of a single-acting cylinder, except for the volume of the piston rod.



The air flow requirements of a cylinder in terms of cfm should not be confused with compressor ratings which are given in terms of free air. If compressor capacity is involved in the consideration of cylinder air requirements it will be necessary to convert cfm values to free air values. This relationship varies for different gauge pressures.

Thrust (pounds) = operating pressure x area of cylinder bore.

Note: That on the "out" stroke the air pressure is working on the entire piston area but on the "in" stroke the air pressure works on the piston area less the rod area.

Graph b-4 and **b-5** offer a simple means to select pneumatic components for dynamic cylinder applications. It is only necessary to know the force required, the desired speed and the pressure which can be maintained at the conditions relative to air line sizes, system layout, friction,

inlet to the F-R-L "Combo." The graphs assume average etc. At higher speeds, consider appropriate cushioning of cylinders.

The general procedure to follow when using these graphs is:

1. Select the appropriate graph depending upon the pressure which can be maintained to the system – **graph b-4** for 100 psig and **graph b-5** for 80 psig.

2. Determine appropriate cylinder bore. Values underneath the diagonal cylinder bore lines indicate the maximum recommended dynamic thrust developed while the cylinder is in motion. The data in the table at the bottom of each graph indicates available static force applications in which clamping force is a prime consideration in determining cylinder bore.

THIS GRAPH IS DETERMINED BY HAVING 100 PSIG AVAILABLE UNDER FLOWING CONDITIONS.

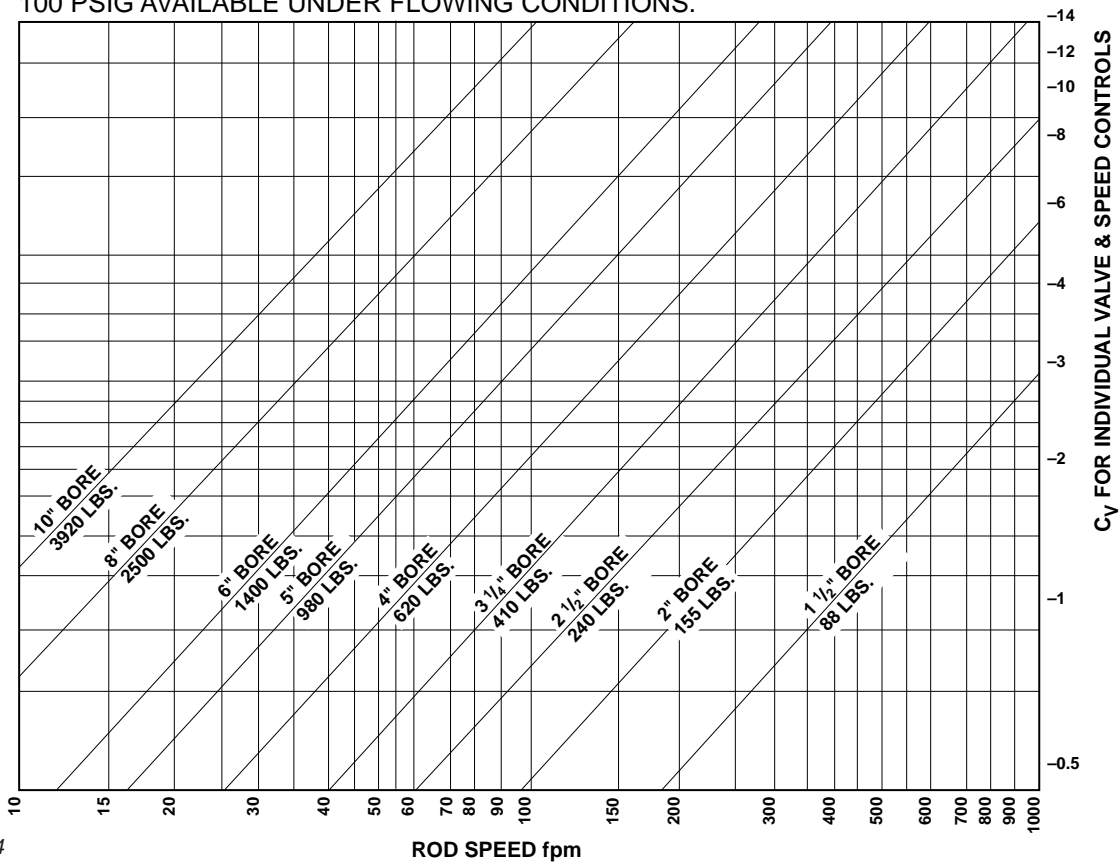

graph b-4

**Table b-8
Thrust Developed**

BORE SIZE	1 1/2"	2"	2 1/2"	3 1/4"	4"	5"	6"	8"	10"
DYNAMIC THRUST (lb)	88	155	240	410	620	980	1400	2500	3920
STATIC THRUST (lb)	177	314	491	830	1250	1960	2820	5020	7850

3. Read upward on appropriate rod speed line to intersection with diagonal cylinder bore line. Read right from intersection point to determine the required C_v of the valve and the speed controls. Both the valve and speed controls must have this C_v .

The following examples illustrate use of the graphs:

Example 1: Assume it is necessary to raise a 900-pound load 24 inches in two seconds. With 100 psig maintained at the inlet to the F-R-L, use **graph b-4**. The 5-inch bore cylinder is capable of developing the required thrust while in motion. Since 24 inches in two seconds is equal to 60 fpm, read upward on the 60 fpm line to the intersection of the 5-inch bore diagonal line. Reading to the right indicates that the required valve and speed controls must each have a C_v of over 1.9.

Example 2: Assume similar conditions to Example 1 except that only 80- psig will be available under flowing conditions. Using **graph b-5**, a 6-inch bore cylinder is indicated. Read upward on the 60 fpm line to the intersection point. Interpolation of the right-hand scale indicates a required valve and speed control C_v of over 2.8.

Example 3: Assume similar conditions to Example 1 except that the load is being moved in a horizontal plane with a coefficient of sliding friction of 0.2. Only a 180-pound thrust is now required (900 lb. x 0.2). Consult **graph b-4**. The 2 1/2 inch bore cylinder will develop sufficient thrust, and at 60 fpm requires a valve and speed control C_v of about 0.5.

THIS GRAPH IS DETERMINED BY HAVING
 80 PSIG AVAILABLE UNDER FLOWING CONDITIONS.

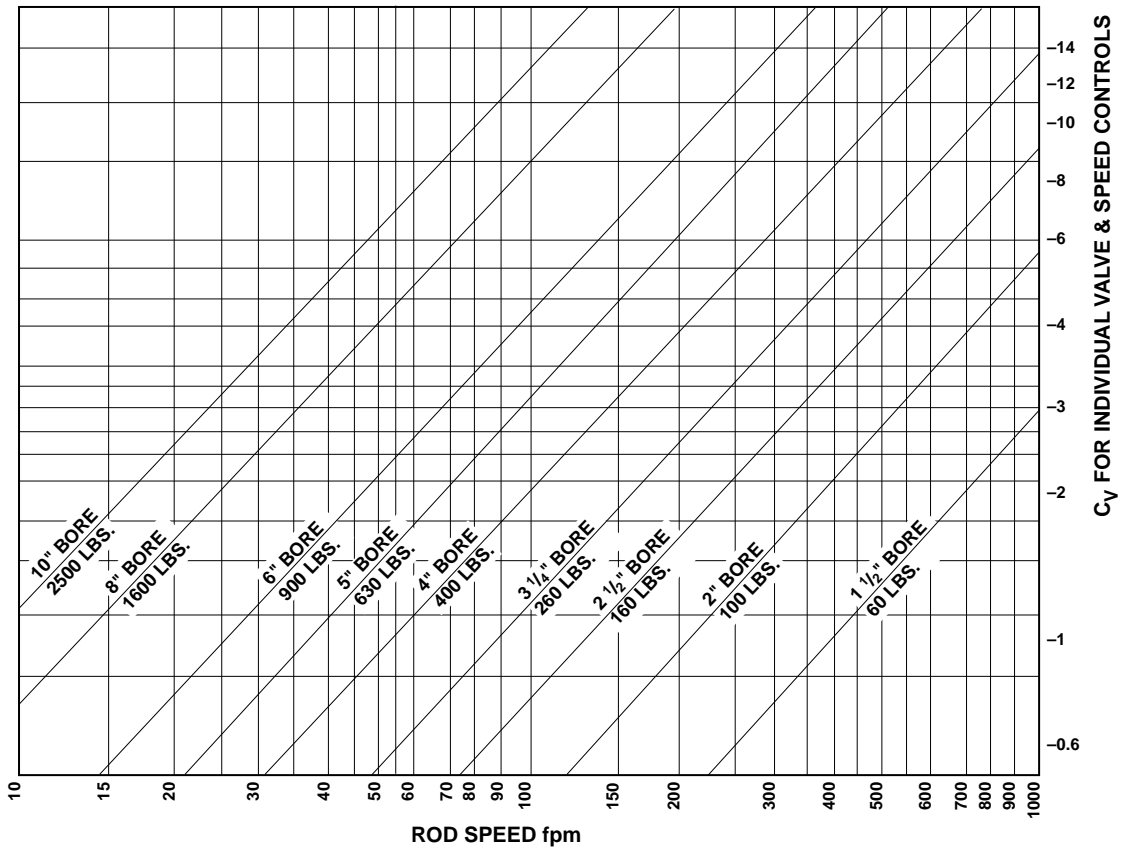

graph b-5

Table b-9
Thrust Developed

BORE SIZE	1 1/2	2	2 1/2	3 1/4	4	5	6	8	10
DYNAMIC THRUST (lb)	60	100	160	260	400	630	900	1600	2500
STATIC THRUST (lb)	141	251	393	663	1000	1570	2260	4010	6280

Common Modifications

Modifications: The following modifications can be supplied on most Parker cylinders.

Metallic Rod Wiper

When specified metallic rod wipers can be supplied instead of the standard synthetic rubber wiperseal. Recommended in applications where contaminants tend to cling to the extended piston rod and would damage the synthetic rubber wiperseal. Installation of metallic rod wiper does not affect cylinder dimensions. It is available at extra cost.

Rod End Boots

Cylinders have a hardened bearing surface on the piston rod to resist external damage, and are equipped with the high efficiency "Wiperseal" to remove external dust and dirt. Exposed piston rods that are subjected to contaminants with air hardening properties, such as paint, should be protected. In such applications, the use of a collapsing cover should be considered. This is commonly referred to as a "boot". Calculate the longer rod end required to accommodate the collapsed length of the boot from the following data.

LF	.13	.13	.13	.13	.13	.13	.13	.10	.10	.10	.10	.10
OD	2 1/4	2 1/4	2 5/8	3	3 3/8	3 3/4	4 3/8	5 1/8	5 5/8	6 1/4	7	7 1/2
MM	1/2	5/8	1	1 3/8	1 3/4	2	2 1/2	3	3 1/2	4	5	5 1/2

To determine extra length of piston rod required to accommodate boot, calculate

$BL = \text{Stroke} \times LF + 1\frac{1}{8}"$

BL + Std. LA = length of piston rod to extend beyond the retainer.

NOTE: Check all Boot O.D's against std. "E" dimension from catalog. This may be critical on foot mounted cylinders.

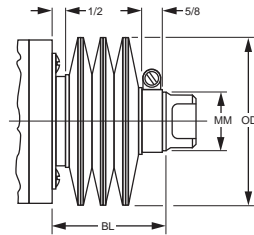

**Heavy Duty Pneumatic Cylinders
Series 2A / 2AN**

Tandem Cylinders

A tandem cylinder is made up of two cylinders mounted in line with pistons connected by a common piston rod and rod seals installed between the cylinders to permit double acting operation of each. Tandem cylinders allow increased output force when mounting width or height are restricted.

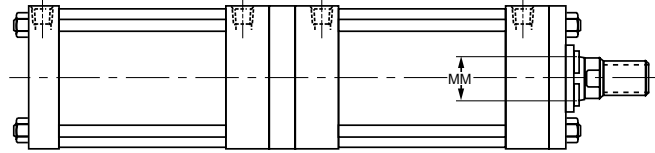

Reduced operating pressure is required for this construction. Contact factory.

Duplex Cylinders

A duplex cylinder is made up of two cylinders mounted in line with pistons not connected and with rod seals installed between the cylinders to permit double acting operation of each. Cylinders may be mounted with piston rod to piston (as shown) or back to back and are generally used to provide three position operation.

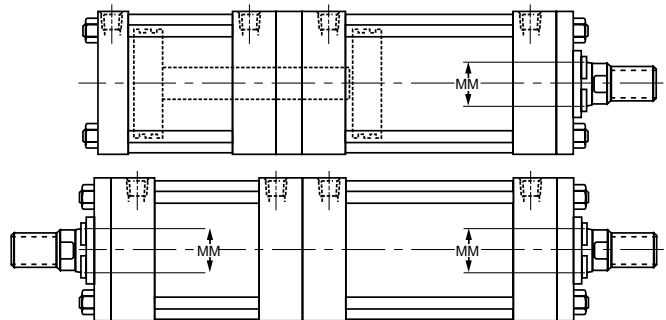

Reduced operating pressure is required for this construction. Contact factory.

Cylinder Weights

The weights shown in Tables A and B are for Parker Series 2A and 2AN cylinders with various piston rod diameters. To determine the net weight of a cylinder, first select the proper basic weight for zero stroke, then calculate the weight of the cylinder stroke and add the result to the basic weight. For extra rod extension use piston rod weights

per inch shown in Table B. Weights of cylinders with intermediate rods may be estimated from table below by taking the difference between the piston rod weights per inch and adding it to the Code 1 weight for the cylinder bore size involved.

Table A Cylinder Weights, in pounds, for Series 2A and 2AN cylinders

Bore Size	Rod Dia.	Single Rod Cylinders Basic Wt. Zero Stroke		Add Per Inch of Stroke	Double Rod Cylinders Basic Wt. Zero Stroke		Add Per Inch of Stroke
		T, TB, TC, TD, F, H, J	BB, C, D, DB DD, HB, JB	2A, 2AN	KF, KJ KT KTB, KTD	KC, KD KDD, KJB	2A, 2AN
1"	1/2"	2.5	2.9	.20	4.7	5.5	.40
	5/8"	2.6	3.0	.23	4.9	5.7	.46
1 1/2"	5/8"	3.7	4.3	.3	4.2	4.8	.6
	1"	4.5	5.1	.4	5.8	6.7	.8
2"	5/8"	6.5	6.9	.5	8.2	8.6	1.0
	1"	7.0	7.5	.63	9.0	9.5	1.3
	1 3/8"	8.5	8.9	.8	11.2	11.6	1.6
2 1/2"	5/8"	9.0	9.7	.6	11.4	12.1	1.2
	1"	9.5	10.0	.73	12.0	12.5	1.5
	1 3/4"	13.2	13.6	1.1	19.8	20.5	2.2
3 1/4"	1"	16.5	17.5	.8	22.0	23.0	1.6
	1 3/8"	17.0	18.0	1.0	22.5	23.5	2.0
	2"	27.0	28.0	1.4	43.0	44.0	2.8
4"	1"	26.0	31.0	1.0	33.0	38.0	2.0
	1 3/8"	26.5	31.5	1.2	33.5	38.5	2.5
	2 1/2"	36.0	42.0	2.0	53.0	58.0	4.0
5"	1"	39.0	46.0	1.1	48.0	55.0	2.2
	1 3/8"	39.5	46.5	1.3	48.5	55.5	2.6
	3 1/2"	63.0	66.0	3.6	96.0	103.0	7.2
6"	1 3/8"	68.0	77.0	1.5	80.0	89.0	3.0
	4"	100.0	102.0	4.5	144.0	153.0	9.0
7"	1 3/8"	80.0	85.0	2.0	92.0	97.0	4.0
	2"	82.0	87.0	3.5	96.0	101.0	7.0
8"	1 3/8"	94.0	99.0	2.0	108.0	113.0	4.0
	5 1/2"	168.0	172.0	8.0	256.0	261.0	16.0
10"	1 3/4"	182.0	188.0	2.5	178.0	184.0	5.0
	5 1/2"	258.0	264.0	8.5	330.0	335.0	17.0
12"	2"	274.0	282.0	3.5	270.0	280.0	7.0
	5 1/2"	350.0	358.0	9.5	420.0	430.0	19.0
14"	2 1/2"	435.0	448.0	4.5	440.0	655.0	9.0
	5 1/2"	510.0	519.0	10.0	490.0	705.0	20.0

Table B

Rod Dia.	Piston Rod Wt. Per Inch	Rod Dia.	Piston Rod Wt. Per Inch	Rod Dia.	Piston Rod Wt. Per Inch
5/8"	.09	2"	.89	4"	3.56
1"	.22	2 1/2"	1.40	4 1/2"	4.51
1 3/8"	.42	3"	2.00	5"	5.56
1 3/4"	.68	3 1/2"	2.72	5 1/2"	6.72



1.00" through 14.00" Bore

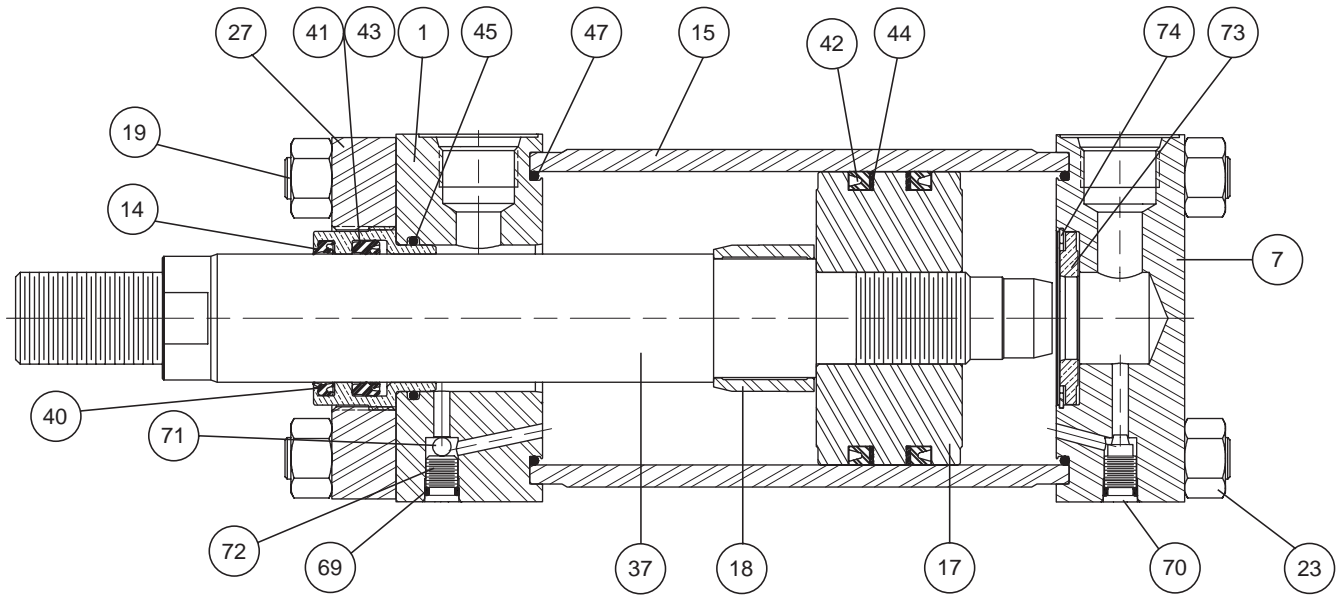

Piston and Rod Assemblies

Factory assembled piston and rod assemblies (that include seals for piston type specified) are recommended.

Tie Rod Torque

Bore Ø	Tie Rod Torque Series 2A
1.00	35-40 lb-in
1.50	60-70 lb-in
2.00	11-12 lb-ft
2.50	11-12 lb-ft
3.25	25-26 lb-ft
4.00	25-26 lb-ft
5.00	60-64 lb-ft
6.00	60-64 lb-ft
7.00	90-94 lb-ft
8.00	110-114 lb-ft
10.00	148-152 lb-ft
12.00	172-176 lb-ft
14.00	275-279 lb-ft

Parts List — 1.00" through 14.00" Bore

Symbol	Description
1	Head
7	Cap
14	Rod Gland
15	Cylinder tube
17	Piston, lipseal type
18	Cushion sleeve, rod head cushion
19	Tie rod
23	Tie rod nut
27	Retainer
37	Piston rod, single rod type
40	Rod Wiper
41	Rod Seal

Symbol	Description
42	Lipseal, piston
43 ¹	Back-up washer, rod seal
44	Back-up washer, piston
45	Gland O-ring
47	O-ring, cylinder tube to head and cap seal
69	O-ring, cushion adjustment and check valve plug screw
70	Needle, cushion adjustment valve
71	Ball, cushion check valve
72	Plug screw, cushion check valve
73	Bushing, float check, cushion on cap end
74	Retaining ring, float check cushion bushing

¹ Item 43, back up washer is required for class 2, 3, 4 & 5 rod seal material.

1.00" through 14.00" Bore

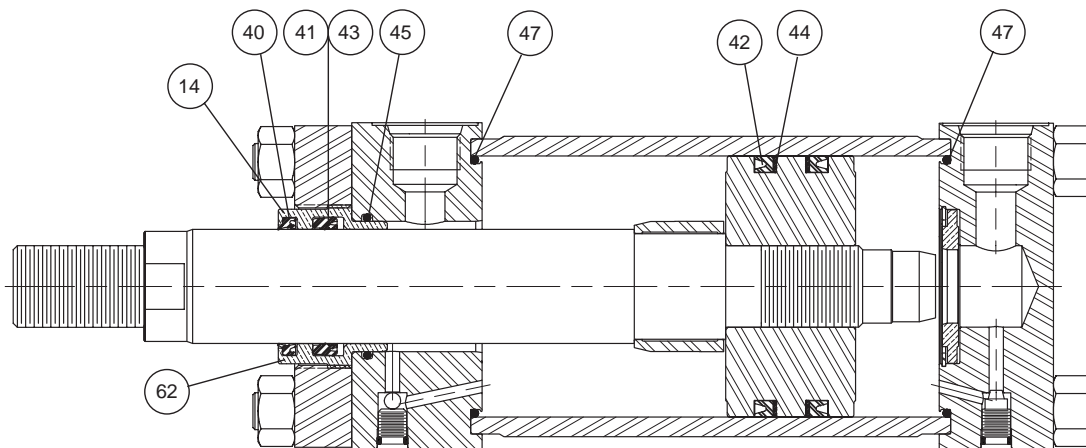

Symbol	Description
14	Rod Gland
40	Rod Wiper
41	Rod Seal
42	Piston Lipseal
43	Rod Seal Back-up Washer
44	Piston Seal Back-up Washer
45	Gland to head o-ring
47	End seal o-ring
62	Gland Cartridge Kit ¹

¹ Gland Cartridge Kit contains: 14, 40, 41, 43 (seal class 2, 3, 4, & 5 only) and 45.

Series 2A Service Kit Numbers – Gland Cartridge Kits and Rod Seal Kits

Rod Ø	Seal Type			
	Class 1 Service (Nitrile)		Class 5 Service ² (Fluorocarbon)	
	Gland Cartridge Kits ¹	Rod Seal Kits ³	Gland Cartridge Kits ¹	Rod Seal Kits ³
0.500	RG2AHL0051	RK2AHL0051	RG2AHL0055	RK2AHL0055
0.625	RG2AHL0061	RK2AHL0061	RG2AHL0065	RK2AHL0065
1.000	RG2AHL0101	RK2AHL0101	RG2AHL0105	RK2AHL0105
1.375	RG2AHL0131	RK2AHL0131	RG2AHL0135	RK2AHL0135
1.750	RG2AHL0171	RK2AHL0171	RG2AHL0175	RK2AHL0175
2.000	RG2AHL0201	RK2AHL0201	RG2AHL0205	RK2AHL0205
2.500	RG2AHL0251	RK2AHL0251	RG2AHL0255	RK2AHL0255
3.000	RG2AHL0301	RK2AHL0301	RG2AHL0305	RK2AHL0305
3.500	RG2AHL0351	RK2AHL0351	RG2AHL0355	RK2AHL0355
4.000	RG2AHL0401	RK2AHL0401	RG2AHL0405	RK2AHL0405
4.500	RG2AHL0451	RK2AHL0451	RG2AHL0455	RK2AHL0455
5.000	RG2AHL0501	RK2AHL0501	RG2AHL0505	RK2AHL0505
5.500	RG2AHL0551	RK2AHL0551	RG2AHL0555	RK2AHL0555

² Series 2A rod gland cartridge kit and rod seal kit, part numbers shown identify class 5 seals. To order class 3 seals substitute 3 as required for the last digit of the kit number.

³ Rod Seal Kits contain items 40, 41, 45 (43 class 3 & 5 only).

⁴ Piston Lipseal Kits – (Includes Cylinder Body End Seals). Contain two each of items 47, 42, & 44.

Series 2A Piston Seal Kits and Body Seal Kits

Bore Ø	Class 1 Service ⁵	
	Piston Lipseal Kits ⁴	Body Seal Kits
1.00	PK1002A001	CB102HL001
1.50	PK1502A001	CB152HL001
2.00	PK2002A001	CB202HL001
2.50	PK2502A001	CB252HL001
3.25	PK3202A001	CB322A0001
4.00	PK4002A001	CB402A0001
5.00	PK5002A001	CB502A0001
6.00	PK6002A001	CB602A0001
7.00	PK7002A001	CB702A0001
8.00	PK8002A001	CB802A0001
10.00	PK9002A001	CB902A0001
12.00	PK9202A001	CB922A0001
14.00	PK9402A001	CB942A0001

⁵ Series 2A piston seal kit and body seal kit part numbers shown identify class 1 seals. To order class 3 or 5 piston seal kits or body seal kits, substitute 3 or 5 as required for the last digit of the kit number.

Retainer Bolt Torque for Cylinders with Bolt-on Gland Retainers

Torque values are for bolts installed with lubrication.

Screw Size	Torque
3/8"	41 - 43 lb-ft

Gland Cartridges and Rod Seals Piston and Body Seal Kits

For Series "2AN" Air Cylinders

Gland Cartridge Kit

RG kit contains 1 each of the following:
symbol 14, gland, threaded cartridge type
symbol 40, rod Wiperseal
symbol 41, rod Lipseal
symbol 45, O-ring, gland to head seal
symbol 131, wick } 3" to 5 1/2"
symbol 132, washer } rods only

Service kits of expendable parts for fluid power cylinders are stocked in principal industrial locations across the U.S.A. and other countries. For prompt delivery and complete information, contact your nearest distributor or Parker Hannifin office.

Service kits of expendable parts for fluid power cylinders are available for Class 1 fluid service.

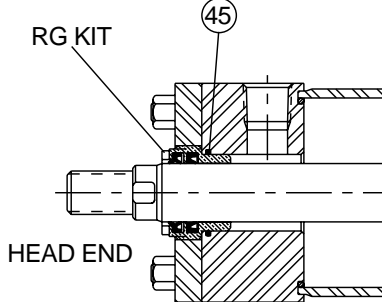
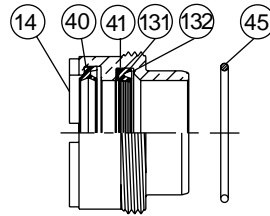

Rod Seal Kit

RK kit contains 1 each of the following:
symbol 40, rod Wiperseal
symbol 41, rod Lipseal
symbol 45, O-ring, gland to head seal
symbol 131, wick } 3" to 5 1/2"
symbol 132, washer } rods only

Standard Seals – Class 1 Service Kits are standard, and contain seals of Nitrile (Buna-N) elastomers. These seals are suitable for use when air is in the operating medium.

The recommended operating temperature range for Class 1 seals is -10°F to +165°F. These seals will function at temperatures up to 200°F with reduced life.

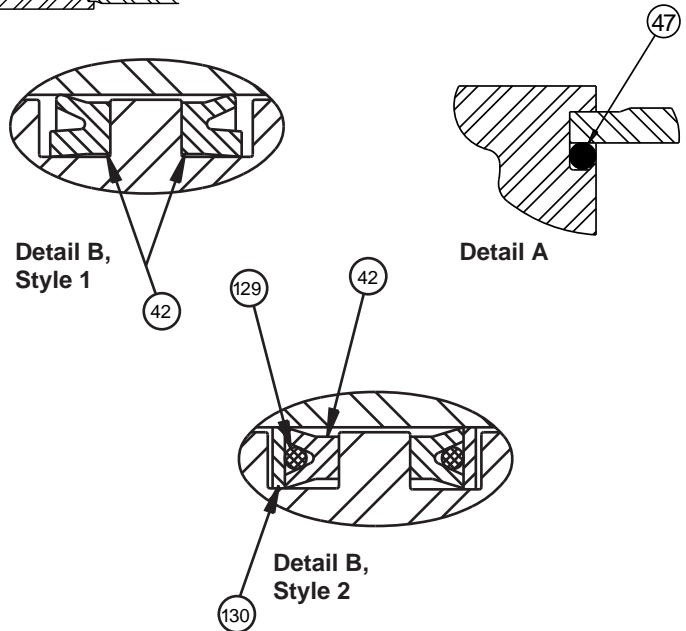
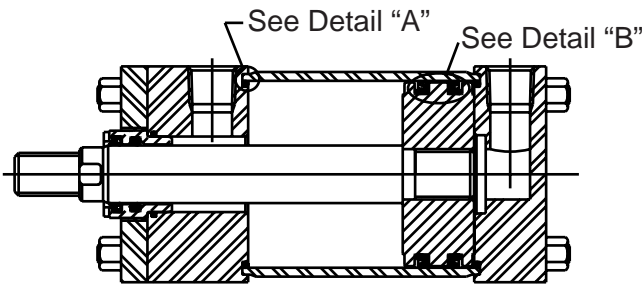

Piston Seal Kits

PK kits for Series 2AN cylinders contain 2 each of the following:

symbol 42, Lipseal, piston
symbol 47, O-ring, cylinder body to head and cap seal
symbol 129, wick } 14" bore only (Style 2)
symbol 130, washer }

Cylinder Body Seal Kits

CB kits for Series 2AN Air cylinders contain 2 each of:

symbol 47, O-rings

Bore Size	PK Piston Seal Kit No. For Series 2AN	CB Cylinder Body Seal Kit For Series 2AN
1"	PK1002AN01	CB102HL001
1 1/2"	PK1502AN01	CB152HL001
2"	PK2002AN01	CB202HL001
2 1/2"	PK2502AN01	CB252HL001
3 1/4"	PK3202AN01	CB322A0001
4"	PK4002AN01	CB402A0001
5"	PK5002AN01	CB502A0001
6"	PK6002AN01	CB602A0001
7"	PK7002AN01	CB702A0001
8"	PK8002AN01	CB802A0001
10"	PK9002AN01	CB902A0001
12"	PK9202AN01	CB922A0001
14"	PK9402AN01	CB942A0001

Rod Dia.	RG Gland Cartridge Kit No. Includes RK Kit	RK Rod Seal Kit No. Contains Rod Seals
1/2"	RG2AN00051	RK2AN00051
5/8"	RG2AN00061	RK2AN00061
1"	RG2AN00101	RK2AN00101
1 3/8"	RG2AN00131	RK2AN00131
1 3/4"	RG2AN00171	RK2AN00171
2"	RG2AN00201	RK2AN00201
2 1/2"	RG2AN00251	RK2AN00251
3"	RG2AN00301	RK2AN00301
3 1/2"	RG2AN00351	RK2AN00351
4"	RG2AN00401	RK2AN00401
4 1/2"	RG2AN00451	RK2AN00451
5"	RG2AN00501	RK2AN00501
5 1/2"	RG2AN00551	RK2AN00551

Gland Cartridge Wrenches

Parker's exclusive gland cartridge design makes gland replacement only a minute's work...and the Gland Cartridge Wrench Set makes it even simpler. A specially designed face-type gland wrench with flared lugs slips into an exact, sure fit on the gland, while a self-locking spanner wrench grips the gland wrench securely. No fumbling for adjustment – no accidental scoring of the piston rod, the job is done quickly...easily...safely.

You can order the Cartridge Wrench or Spanner Wrench to fit the piston rod size used in your Parker Hannifin Cylinder.

Rod Diameter	Gland Wrench (Symbol 63)	Spanner Wrench (Symbol 63-A)
0.625"	0695900000	0116760000
1.000"	0695910000	
1.375"	0695920000	0117030000
1.750"	0695930000	0116770000
2.000"	0695940000	
2.500"	0695950000	0116770000
3.000"	0695960000	
3.500"	0695970000	
4.000"	0695980000	0116780000
4.500"	0838770000	
5.000"	0695990000	
5.500"	0696000000	

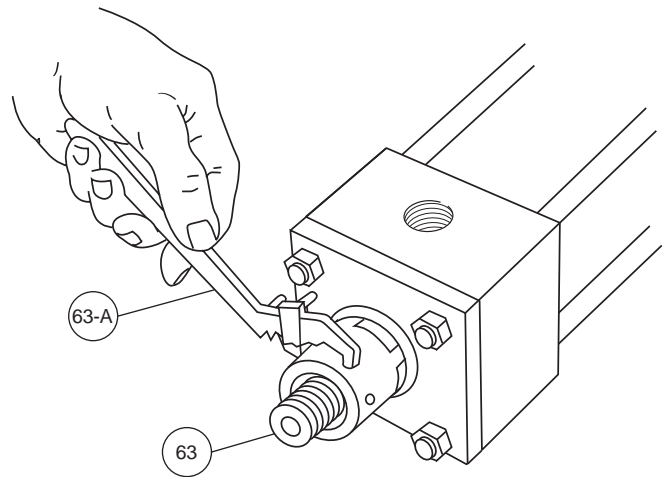

Safety Guide for Selecting and Using Hydraulic, Pneumatic Cylinders and Their Accessories

WARNING: ⚠ FAILURE OF THE CYLINDER, ITS PARTS, ITS MOUNTING, ITS CONNECTIONS TO OTHER OBJECTS, OR ITS CONTROLS CAN RESULT IN:

- Unanticipated or uncontrolled movement of the cylinder or objects connected to it.
- Falling of the cylinder or objects held up by it.
- Fluid escaping from the cylinder, potentially at high velocity.

THESE EVENTS COULD CAUSE DEATH OR PERSONAL INJURY BY, FOR EXAMPLE, PERSONS FALLING FROM HIGH LOCATIONS, BEING CRUSHED OR STRUCK BY HEAVY OR FAST MOVING OBJECTS, BEING PUSHED INTO DANGEROUS EQUIPMENT OR SITUATIONS, OR SLIPPING ON ESCAPED FLUID.

Before selecting or using Parker Hannifin Corporation (the Company) cylinders or related accessories, it is important that you read, understand and follow the following safety information. Training is advised before selecting and using the Company's products.

1.0 General Instructions

1.1 Scope – This safety guide provides instructions for selecting and using (including assembling, installing, and maintaining) cylinder products. This safety guide is a supplement to and is to be used with the specific Company publications for the specific cylinder products that are being considered for use.

1.2 Fail Safe – Cylinder products can and do fail without warning for many reasons. All systems and equipment should be designed in a fail-safe mode so that if the failure of a cylinder product occurs people and property won't be endangered.

1.3 Distribution – Provide a free copy of this safety guide to each person responsible for selecting or using cylinder products. Do not select or use the Company's cylinders without thoroughly reading and understanding this safety guide as well as the specific Company publications for the products considered or selected.

1.4 User Responsibility – Due to very wide variety of cylinder applications and cylinder operating conditions, the Company does not warrant that any particular cylinder is suitable for any specific application. This safety guide does not analyze all technical parameters that must be considered in selecting a product. The hydraulic and pneumatic cylinders outlined in this catalog are designed to the Company's design guidelines and do not necessarily meet the design guideline of other agencies such as American Bureau of Shipping, ASME Pressure Vessel Code etc. The user, through its own analysis and testing, is solely responsible for:

- Making the final selection of the cylinders and related accessories.
- Determining if the cylinders are required to meet specific design requirements as required by the Agency(s) or industry standards covering the design of the user's equipment.
- Assuring that the user's requirements are met, OSHA requirements are met, and safety guidelines from the applicable agencies such as but not limited to ANSI are followed and that the use presents no health or safety hazards.
- Providing all appropriate health and safety warnings on the equipment on which the cylinders are used.

1.5 Additional Questions – Call the appropriate Company technical service department if you have any questions or require any additional information. See the Company publication for the product being considered or used, or call 1-847-298-2400, or go to www.parker.com, for telephone numbers of the appropriate technical service department.

2.0 Cylinder and Accessories Selection

2.1 Seals – Part of the process of selecting a cylinder is the selection of seal compounds. Before making this selection, consult the "seal information page(s)" of the publication for the series of cylinders of interest.

The application of cylinders may allow fluids such as cutting fluids, wash down fluids etc. to come in contact with the external area of the cylinder. These fluids may attack the piston rod wiper and or the primary seal and must be taken into account when selecting and specifying seal compounds.

Dynamic seals will wear. The rate of wear will depend on many operating factors. Wear can be rapid if a cylinder is mis-aligned or if the cylinder has been improperly serviced. The user must take seal wear into consideration in the application of cylinders.

2.2 Piston Rods – Possible consequences of piston rod failure or separation of the piston rod from the piston include, but are not limited to are:

- Piston rod and or attached load thrown off at high speed.
- High velocity fluid discharge.
- Piston rod extending when pressure is applied in the piston retract mode.

Piston rods or machine members attached to the piston rod may move suddenly and without warning as a consequence of other conditions occurring to the machine such as, but not limited to:

- Unexpected detachment of the machine member from the piston rod.

- Failure of the pressurized fluid delivery system (hoses, fittings, valves, pumps, compressors) which maintain cylinder position.
- Catastrophic cylinder seal failure leading to sudden loss of pressurized fluid.
- Failure of the machine control system.

Follow the recommendations of the "Piston Rod Selection Chart and Data" in the publication for the series of cylinders of interest. The suggested piston rod diameter in these charts must be followed in order to avoid piston rod buckling.

Piston rods are not normally designed to absorb bending moments or loads which are perpendicular to the axis of piston rod motion. These additional loads can cause the piston rod to fail. If these types of additional loads are expected to be imposed on the piston rod, their magnitude should be made known to our engineering department.

The cylinder user should always make sure that the piston rod is securely attached to the machine member.

On occasion cylinders are ordered with double rods (a piston rod extended from both ends of the cylinder). In some cases a stop is threaded on to one of the piston rods and used as an external stroke adjuster. On occasions spacers are attached to the machine member connected to the piston rod and also used as a stroke adjuster. In both cases the stops will create a pinch point and the user should consider appropriate use of guards. If these external stops are not perpendicular to the mating contact surface, or if debris is trapped between the contact surfaces, a bending moment will be placed on the piston rod, which can lead to piston rod failure. An external stop will also negate the effect of cushioning and will subject the piston rod to impact loading. Those two (2) conditions can cause piston rod failure. Internal stroke adjusters are available with and without cushions. The use of external stroke adjusters should be reviewed with our engineering department.

The piston rod to piston and the stud to piston rod threaded connections are secured with an anaerobic adhesive. The strength of the adhesive decreases with increasing temperature. Cylinders which can be exposed to temperatures above +250°F (+121°C) are to be ordered with a non studded piston rod and a pinned piston rod joint.

2.3 Cushions – Cushions should be considered for cylinder applications when the piston velocity is expected to be over 4 inches/second.

Cylinder cushions are normally designed to absorb the energy of a linear applied load. A rotating mass has considerably more energy than the same mass moving in a linear mode. Cushioning for a rotating mass application should be reviewed by our engineering department.

2.4 Cylinder Mountings – Some cylinder mounting configurations may have certain limitations such as but not limited to minimum stroke for side or foot mounting cylinders or pressure de-ratings for certain mounts. Carefully review the catalog for these types of restrictions.

Always mount cylinders using the largest possible high tensile alloy steel socket head cap screws that can fit in the cylinder mounting holes and torque them to the manufacturer's recommendations for their size.

2.5 Port Fittings – Hydraulic cylinders applied with meter out or deceleration circuits are subject to intensified pressure at piston rod end.

The rod end pressure is approximately equal to:

$$\frac{\text{operating pressure} \times \text{effective cap end area}}{\text{effective rod end piston area}}$$

Contact your connector supplier for the pressure rating of individual connectors.

3.0 Cylinder and Accessories Installation and Mounting

3.1 Installation

3.1.1 – Cleanliness is an important consideration, and cylinders are shipped with the ports plugged to protect them from contaminants entering the ports. These plugs should not be removed until the piping is to be installed. Before making the connection to the cylinder ports, piping should be thoroughly cleaned to remove all chips or burrs which might have resulted from threading or flaring operations.

3.1.2 – Cylinders operating in an environment where air drying materials are present such as fast-drying chemicals, paint, or weld splatter, or other hazardous conditions such as excessive heat, should have shields installed to prevent damage to the piston rod and piston rod seals.

3.1.3 – Proper alignment of the cylinder piston rod and its mating component on the machine should be checked in both the extended and retracted positions. Improper alignment will result in excessive rod gland and/or cylinder bore wear. On fixed mounting cylinders attaching the piston rod while the rod is retracted will help in achieving proper alignment.

3.1.4 – Sometimes it may be necessary to rotate the piston rod in order to thread the piston rod into the machine member. This operation must always be done with zero pressure being applied to either side of the piston. Failure to follow this procedure may result in loosening the piston to rod-threaded connection. In some rare cases the turning of the piston rod may rotate a threaded head and loosen it from the cylinder body. Confirm that this condition is not occurring. If it does, re-tighten the head firmly against the cylinder body.

For double rod cylinders it is also important that when attaching or detaching the piston rod from the machine member that the torque be applied to the piston rod end of the cylinder that is directly attaching to the machine member with the opposite end unrestrained. If the design of the machine is such that only the rod end of the cylinder opposite to where the rod attaches to the machine member can be rotated, consult the factory for further instructions.

3.2 Mounting Recommendations

3.2.1 – Always mount cylinders using the largest possible high tensile alloy steel socket head screws that can fit in the cylinder mounting holes and torque them to the manufacturer's recommendations for their size.

3.2.2 – Side-Mounted Cylinders – In addition to the mounting bolts, cylinders of this type should be equipped with thrust keys or dowel pins located so as to resist the major load.

3.2.3 – Tie Rod Mounting – Cylinders with tie rod mountings are recommended for applications where mounting space is limited. Nuts used for this mounting style should be torqued to the same value as the tie rods for that bore size.

3.2.4 – Flange Mount Cylinders – The controlled diameter of the rod gland extension on head end flange mount cylinders can be used as a pilot to locate the cylinders in relation to the machine. After alignment has been obtained, the flanges may be drilled for pins or dowels to prevent shifting.

3.2.5 – Trunnion Mountings – Cylinders require lubricated bearing blocks with minimum bearing clearances. Bearing blocks should be carefully aligned and rigidly mounted so the trunnions will not be subjected to bending moments. The rod end should also be pivoted with the pivot pin in line and parallel to axis of the trunnion pins.

3.2.6 – Clevis Mountings – Cylinders should be pivoted at both ends with centerline of pins parallel to each other. After cylinder is mounted, be sure to check to assure that the cylinder is free to swing through its working arc without interference from other machine parts.

4.0 Cylinder and Accessories Maintenance, Troubleshooting and Replacement

4.1 Storage – At times cylinders are delivered before a customer is ready to install them and must be stored for a period of time. When storage is required the following procedures are recommended.

4.1.1 – Store the cylinders in an indoor area which has a dry, clean and noncorrosive atmosphere. Take care to protect the cylinder from both internal corrosion and external damage.

4.1.2 – Whenever possible cylinders should be stored in a vertical position (piston rod up). This will minimize corrosion due to possible condensation which could occur inside the cylinder. This will also minimize seal damage.

4.1.3 – Port protector plugs should be left in the cylinder until the time of installation.

4.1.4 – If a cylinder is stored full of hydraulic fluid, expansion of the fluid due to temperature changes must be considered. Installing a check valve with free flow out of the cylinder is one method.

4.1.5 – When cylinders are mounted on equipment that is stored outside for extended periods, exposed unpainted surfaces, e.g. piston rod, must be coated with a rust-inhibiting compound to prevent corrosion.

4.2 Cylinder Trouble Shooting

4.2.1 – External Leakage

4.2.1.1 – Rod seal leakage can generally be traced to worn or damaged seals. Examine the piston rod for dents, gouges or score marks, and replace piston rod if surface is rough.

Rod seal leakage could also be traced to bearing wear. If clearance is excessive, replace rod bearing and seal. Rod seal leakage can also be traced to seal deterioration. If seals are soft or gummy or brittle, check compatibility of seal material with lubricant used if air cylinder, or operating fluid if hydraulic cylinder. Replace with seal material, which is compatible with these fluids. If the seals are hard or have lost elasticity, it is usually due to exposure to temperatures in excess of 165°F. (+74°C). Shield the cylinder from the heat source to limit temperature to 350°F. (+177°C.) and replace with fluorocarbon seals.

4.2.1.2 – Cylinder body seal leak can generally be traced to a loose head. Torque the head to manufacturer's recommendation for that bore size.

Excessive pressure can also result in cylinder body seal leak. Determine maximum pressure to rated limits. Replace seals and retorque head as in paragraph above. Excessive pressure can also result in cylinder body seal leak. Determine if the pressure rating of the cylinder has been exceeded. If so, bring the operating pressure down to the rating of the cylinder and have the head replaced.

Pinched or extruded cylinder body seal will also result in a leak. Replace cylinder body seal and retorque as in paragraph above.

Cylinder body seal leakage due to loss of radial squeeze which shows up in the form of flat spots or due to wear on the O.D. or I.D. – Either of these are symptoms of normal wear due to high cycle rate or length of service. Replace seals as per paragraph above.

4.2.2 – Internal Leakage

4.2.2.1 – Piston seal leak (by-pass) 1 to 3 cubic inches per minute leakage is considered normal for piston ring construction. Virtually no static leak with lipseal type seals on piston should be expected. Piston seal wear is a usual cause of piston seal leakage. Replace seals as required.

4.2.2.2 – With lipseal type piston seals excessive back pressure due to over-adjustment of speed control valves could be a direct cause of rapid seal wear. Contamination in a hydraulic system can result in a scored cylinder bore, resulting in rapid seal wear. In either case, replace piston seals as required.

4.2.2.3 – What appears to be piston seal leak, evidenced by the fact that the cylinder drifts, is not always traceable to the piston. To make sure, it is suggested that one side of the cylinder piston be pressurized and the fluid line at the opposite port be disconnected. Observe leakage. If none is evident, seek the cause of cylinder drift in other component parts in the circuit.

4.2.3 – Cylinder Fails to Move the Load

4.2.3.1 – Pneumatic or hydraulic pressure is too low. Check the pressure at the cylinder to make sure it is to circuit requirements.

4.2.3.2 – Piston Seal Leak – Operate the valve to cycle the cylinder and observe fluid flow at valve exhaust ports at end of cylinder stroke. Replace piston seals if flow is excessive.

4.2.3.3 – Cylinder is undersized for the load – Replace cylinder with one of a larger bore size.

4.3 Erratic or Chatter Operation

4.3.1 – Excessive friction at rod bearing or piston bearing due to load misalignment – Correct cylinder-to-load alignment.

4.3.2 – Cylinder sized too close to load requirements – Reduce load or install larger cylinder.

4.3.3 – Erratic operation could be traced to the difference between static and kinetic friction. Install speed control valves to provide a back pressure to control the stroke.

4.4 Cylinder Modifications, Repairs, or Failed Component – Cylinders as shipped from the factory are not to be disassembled and/or modified. If cylinders require modifications, these modifications must be done at company locations or by the Company's certified facilities. The Cylinder Division Engineering Department must be notified in the event of a mechanical fracture or permanent deformation of any cylinder component (excluding seals). This includes a broken piston rod, head, mounting accessory or any other cylinder component. The notification should include all operation and application details. This information will be used to provide an engineered repair that will prevent recurrence of the failure.

It is allowed to disassemble cylinders for the purpose of replacing seals or seal assemblies. However, this work must be done by strictly following all the instructions provided with the seal kits.

Manufacturing Locations

Regional Plants

California

221 Helicopter Circle
Corona, CA 92880
Tel.: (951) 280-3800
Fax: (951) 280-3808
Fax: (800) 869-9886

Georgia

1300 Six Flags Road
Lithia Springs, GA 30122
Tel.: (770) 819-3400
Fax: (800) 437-3498

Indiana

Goodland Plant
715 South Iroquois Street
Goodland, IN 47948
Tel.: (219) 297-3182
Fax: (800) 328-8120

Michigan

900 Plymouth Road
Plymouth, MI 48170
Tel.: (734) 455-1700
Fax: (734) 455-1007

Oregon

29289 Airport Road
Eugene, OR 97402-0079
Tel.: (541) 689-9111
Fax: (541) 688-6771
Fax: (800) 624-7996

Notes

The items described in this document and other documents and descriptions provided by Parker Hannifin Corporation, its subsidiaries and its authorized distributors ("Seller") are hereby offered for sale at prices to be established by Seller. This offer and its acceptance by any customer ("Buyer") shall be governed by all of the following Terms and Conditions. Buyer's order for any item described in its document, when communicated to Seller verbally, or in writing, shall constitute acceptance of this offer. All goods, services or work described will be referred to as "Products".

1. Terms. All sales of Products by Seller are expressly conditioned upon, and will be governed by the acceptance of, these Terms. These Terms are incorporated into any Quote provided by Seller to Buyer. Buyer's order for any Products whether communicated to Seller verbally, in writing, by electronic data interface or other electronic commerce, shall constitute acceptance of these Terms. Seller objects to any contrary or additional terms or conditions of Buyer. Reference in Seller's order acknowledgement to Buyer's purchase order or purchase order number shall in no way constitute an acceptance of any of Buyer's terms or conditions of purchase. No modification to these Terms will be binding on Seller unless agreed to in writing and signed by an authorized representative of Seller.

2. Price; Payment. The Products set forth in the Quote are offered for sale at the prices indicated in the Quote. Unless otherwise specifically stated in the Quote, prices are valid for thirty (30) days and do not include any sales, use, or other taxes or duties. Seller reserves the right to modify prices at any time to adjust for any raw material price fluctuations. Unless otherwise specified by Seller, all prices are F.C.A. Seller's facility (INCOTERMS 2020). All sales are contingent upon credit approval and full payment for all purchases is due thirty (30) days from the date of invoice (or such date as may be specified in the Quote). Unpaid invoices beyond the specified payment date incur interest at the rate of 1.5% per month or the maximum allowable rate under applicable law.

3. Shipment; Delivery; Title and Risk of Loss. All delivery dates are approximate, and Seller is not responsible for damages resulting from any delay. Regardless of the manner of shipment, delivery occurs and title and risk of loss or damage pass to Buyer, upon placement of the Products with the carrier at Seller's facility. Unless otherwise agreed prior to shipment and for domestic delivery locations only, Seller will select and arrange, at Buyer's sole expense, the carrier and means of delivery. When Seller selects and arranges the carrier and means of delivery, freight and insurance costs for shipment to the designated delivery location will be prepaid by Seller and added as a separate line item to the invoice. Buyer shall be responsible for any additional shipping charges incurred by Seller due to Buyer's acts or omissions. Buyer shall not return or repackage any Products without the prior written authorization from Seller, and any return shall be at the sole cost and expense of Buyer.

4. Warranty. The warranty for the Products is as follows: (i) Goods are warranted against defects in material or workmanship for a period of eighteen (18) months from the date of delivery or 2,000 hours of use, whichever occurs first; (ii) Services shall be performed in accordance with generally accepted practices and using the degree of care and skill that is ordinarily exercised and customary in the field to which the Services pertain and are warranted for a period of six (6) months from the date of completion of the Services; and (iii) Software is only warranted to perform in accordance with applicable specifications provided by Seller to Buyer for ninety (90) days from the date of delivery or, when downloaded by a Buyer or end-user, from the date of the initial download. All prices are based upon the exclusive limited warranty stated above, and upon the following disclaimer: **EXEMPTION CLAUSE; DISCLAIMER OF WARRANTY, CONDITIONS, REPRESENTATIONS: THIS WARRANTY IS THE SOLE AND ENTIRE WARRANTY, CONDITION, AND REPRESENTATION, PERTAINING TO PRODUCTS. SELLER DISCLAIMS ALL OTHER WARRANTIES, CONDITIONS, AND REPRESENTATIONS, WHETHER STATUTORY, EXPRESS OR IMPLIED, INCLUDING BUT NOT LIMITED TO THOSE RELATING TO DESIGN, NON-INFRINGEMENT, MERCHANTABILITY, AND FITNESS FOR A PARTICULAR PURPOSE. SELLER DOES NOT WARRANT THAT THE SOFTWARE IS ERROR-FREE OR FAULT-TOLERANT, OR THAT BUYER'S USE THEREOF WILL BE SECURE OR UNINTERRUPTED. UNLESS OTHERWISE AUTHORIZED IN WRITING BY SELLER, THE SOFTWARE SHALL NOT BE USED IN CONNECTION WITH HAZARDOUS OR HIGH RISK ACTIVITIES OR ENVIRONMENTS. EXCEPT AS EXPRESSLY STATED HEREIN, ALL PRODUCTS ARE PROVIDED "AS IS".**

5. Claims; Commencement of Actions. Buyer shall promptly inspect all Products upon receipt. No claims for shortages will be allowed unless reported to Seller within ten (10) days of delivery. Buyer shall notify Seller of any alleged breach of warranty within thirty (30) days after the date the non-conformance is or should have been discovered by Buyer. Any claim or action against Seller based upon breach of contract or any other theory, including tort, negligence, or otherwise must be commenced within twelve (12) months from the date of the alleged breach or other alleged event, without regard to the date of discovery.

6. LIMITATION OF LIABILITY. IN THE EVENT OF A BREACH OF WARRANTY, SELLER WILL, AT ITS OPTION, REPAIR OR REPLACE THE NON-CONFORMING PRODUCT, RE-PERFORM THE SERVICES, OR REFUND THE PURCHASE PRICE PAID WITHIN A REASONABLE PERIOD OF TIME. **IN NO EVENT IS SELLER LIABLE FOR ANY SPECIAL, INDIRECT, INCIDENTAL OR CONSEQUENTIAL DAMAGES INCLUDING ANY LOSS OF REVENUE OR PROFITS, WHETHER BASED IN CONTRACT, TORT OR OTHER LEGAL THEORY. IN NO EVENT SHALL SELLER'S LIABILITY UNDER ANY CLAIM MADE BY BUYER EXCEED THE PURCHASE PRICE PAID FOR THE PRODUCTS.**

7. Confidential Information. Buyer acknowledges and agrees that any technical, commercial, or other confidential information of Seller, including, without limitation, pricing, technical drawings or prints and/or part lists, which has been or will be disclosed, delivered or made available, whether directly or indirectly, to Buyer ("Confidential Information"), has been and will be received in confidence and will remain the property of Seller. Buyer further agrees that it will not use Seller's Confidential Information for any purpose other than for the benefit of Seller.

8. Loss to Buyer's Property. Any tools, patterns, materials, equipment or information furnished by Buyer or which are or become Buyer's property ("Buyer's Property"), will be considered obsolete and may be destroyed by Seller after two (2) consecutive years have elapsed without Buyer ordering the Products manufactured using Buyer's Property. Furthermore, Seller shall not be responsible for any loss or damage to Buyer's Property while it is in Seller's possession or control.

9. Special Tooling. "Special Tooling" includes but is not limited to tools, jigs, fixtures and associated manufacturing equipment acquired or necessary to manufacture Goods. Seller may impose a tooling charge for any Special Tooling. Such Special Tooling shall be and remain Seller's property notwithstanding payment of any charges by Buyer. In no event will Buyer acquire any interest in the Special Tooling, even if such Special Tooling has been specially converted or adapted for manufacture of Goods for Buyer and notwithstanding any charges paid by Buyer. Unless otherwise agreed, Seller has the right to alter, discard or otherwise dispose of any Special Tooling or other property owned by Seller in its sole discretion at any time.

10. Security Interest. To secure payment of all sums due from Buyer, Seller retains a security interest in all Products delivered to Buyer and, Buyer's acceptance of these Terms is deemed to be a Security Agreement under the Uniform Commercial Code. Buyer authorizes Seller as its attorney to execute and file on Buyer's behalf all documents Seller deems necessary to perfect Seller's security interest.

11. User Responsibility. Buyer, through its own analysis and testing, is solely responsible for making the final selection of the Products and assuring that all performance, endurance, maintenance, safety and warning requirements of the application of the Products are met. Buyer must analyze all aspects of the application and follow applicable industry standards, specifications, and any technical information provided with the Quote or the Products, such as Seller's instructions, guides and specifications. If Seller provides options of or for Products based upon data or specifications provided by Buyer, Buyer is responsible for determining that such data and specifications are suitable and sufficient for all applications and reasonably foreseeable uses of the Products. In the event Buyer is not the end-user of the Products, Buyer will ensure such end-user complies with this paragraph.

12. Use of Products, Indemnity by Buyer. Buyer shall comply with all instructions, guides and specifications provided by Seller with the Quote or the Products. Unauthorized Uses. If Buyer uses or resells the Products in any way prohibited by Seller's instructions, guides or specifications, or Buyer otherwise fails to comply with Seller's

instructions, guides and specifications, Buyer acknowledges that any such use, resale, or non-compliance is at Buyer's sole risk. Further, Buyer shall indemnify, defend, and hold Seller harmless from any losses, claims, liabilities, damages, lawsuits, judgments and costs (including attorney fees and defense costs), whether for personal injury, property damage, intellectual property infringement or any other claim, arising out of or in connection with: (a) improper selection, design, specification, application, or any misuse of Products; (b) any act or omission, negligent or otherwise, of Buyer; (c) Seller's use of patterns, tools, equipment, plans, drawings, designs, specifications or other information or things furnished by Buyer; (d) damage to the Products from an external cause, repair or attempted repair by anyone other than Seller, failure to follow instructions, guides and specifications provided by Seller, use with goods not provided by Seller, or opening, modifying, deconstructing, tampering with or repackaging the Products; or (e) Buyer's failure to comply with these Terms. Seller shall not indemnify Buyer under any circumstance except as otherwise provided in these Terms.

13. Cancellations and Changes. Buyer may not cancel or modify, including but not limited to movement of delivery dates for the Products, any order for any reason except with Seller's written consent and upon terms that will indemnify, defend and hold Seller harmless against all direct, incidental and consequential loss or damage and any additional expense. Seller, at any time, may change features, specifications, designs and availability of Products.

14. Limitation on Assignment. Buyer may not assign its rights or obligations without the prior written consent of Seller.

15. Force Majeure. Seller is not liable for delay or failure to perform any of its obligations by reason of events or circumstances beyond its reasonable control. Such circumstances include without limitation: accidents, labor disputes or stoppages, government acts or orders, acts of nature, pandemics, epidemics, other widespread illness, or public health emergency, delays or failures in delivery from carriers or suppliers, shortages of materials, war (whether declared or not) or the serious threat of same, riots, rebellions, acts of terrorism, fire or any reason whether similar to the foregoing or otherwise. Seller will resume performance as soon as practicable after the event of force majeure has been removed. All delivery dates affected by force majeure shall be tolled for the duration of such force majeure and rescheduled for mutually agreed dates as soon as practicable after the force majeure condition ceases to exist. Force majeure shall not include financial distress, insolvency, bankruptcy, or other similar conditions affecting one of the parties, affiliates and/or sub-contractors.

16. Waiver and Severability. Failure to enforce any provision of these Terms will not invalidate that provision; nor will any such failure prejudice either party's right to enforce that provision in the future. Invalidation of any provision of these Terms shall not invalidate any other provision herein and, the remaining provisions will remain in full force and effect.

17. Termination. Seller may terminate any agreement governed by or arising from these Terms for any reason and at any time by giving Buyer thirty (30) days prior written notice. Seller may immediately terminate, in writing, if Buyer: (a) breaches any provision of these Terms, (b) becomes or is deemed insolvent, (c) appoints or has appointed a trustee, receiver or custodian for all or any part of Buyer's property, (d) files a petition for relief in bankruptcy on its own behalf, or one is filed against Buyer by a third party, (e) makes an assignment for the benefit of creditors; or (f) dissolves its business or liquidates all or a majority of its assets.

18. Ownership of Software. Seller retains ownership of all Software supplied to Buyer hereunder. In no event shall Buyer obtain any greater right in and to the Software than a right in the nature of a license limited to the use thereof and subject to compliance with any other terms provided with the Software.

19. Indemnity for Infringement of Intellectual Property Rights. Seller is not liable for infringement of any patents, trademarks, copyrights, trade dress, trade secrets or similar rights ("Intellectual Property Rights") except as provided in this Section. Seller will defend at its expense and will pay the cost of any settlement or damages awarded in an action brought against Buyer based on a third party claim that one or more of the Products sold hereunder infringes the Intellectual Property Rights of a third party in the country of delivery of the Products by Seller to Buyer. Seller's obligation to defend and indemnify Buyer is contingent on Buyer notifying Seller within ten (10) days after Buyer becomes aware of any such claim, and Seller having sole control over the defense of the claim including all negotiations for settlement or compromise. If one or more Products sold hereunder is subject to such a claim, Seller may, at its sole expense and option, procure for Buyer the right to continue using the Products, replace or modify the Products so as to render them non-infringing, or offer to accept return of the Products and refund the purchase price less a reasonable allowance for depreciation. Seller has no obligation or liability for any claim of infringement: (i) arising from information provided by Buyer; or (ii) directed to any Products provided hereunder for which the designs are specified in whole or part by Buyer; or (iii) resulting from the modification, combination or use in a system of any Products provided hereunder. The foregoing provisions of this Section constitute Seller's sole and exclusive liability and Buyer's sole and exclusive remedy for claims of infringement of Intellectual Property Rights.

20. Governing Law. These Terms and the sale and delivery of all Products are deemed to have taken place in, and shall be governed and construed in accordance with, the laws of the State of Ohio, as applicable to contracts executed and wholly performed therein and without regard to conflicts of laws principles. Buyer irrevocably agrees and consents to the exclusive jurisdiction and venue of the courts of Cuyahoga County, Ohio with respect to any dispute, controversy or claim arising out of or relating to the sale and delivery of the Products.

21. Entire Agreement. These Terms, along with the terms set forth in the main body of any Quote, forms the entire agreement between the Buyer and Seller and constitutes the final, complete and exclusive expression of the terms of sale and purchase. In the event of a conflict between any term set forth in the main body of a Quote and these Terms, the terms set forth in the main body of the Quote shall prevail. All prior or contemporaneous written or oral agreements or negotiations with respect to the subject matter shall have no effect. These Terms may not be modified unless in writing and signed by an authorized representative of Seller.

22. Compliance with Laws. Buyer agrees to comply with all applicable laws, regulations, and industry and professional standards, including those of the United States of America, and the country or countries in which Buyer may operate, including without limitation the U.S. Foreign Corrupt Practices Act ("FCPA"), the U.S. Anti-Kickback Act ("Anti-Kickback Act"), U.S. and E.U. export control and sanctions laws ("Export Laws"), the U.S. Food and Drug Administration ("FDA"), and the rules and regulations promulgated by the U.S. Food and Drug Administration ("FDA"), each as currently amended. Buyer agrees to indemnify, defend, and hold harmless Seller from the consequences of any violation of such laws, regulations and standards by Buyer, its employees or agents. Buyer acknowledges that it is familiar with all applicable provisions of the FCPA, the Anti-Kickback Act, Export Laws, the FDA and the FDA and certifies that Buyer will adhere to the requirements thereof and not take any action that would make Seller violate such requirements. Buyer represents and agrees that Buyer will not make any payment or give anything of value, directly or indirectly, to any governmental official, foreign political party or official thereof, candidate for foreign political office, or commercial entity or person, for any improper purpose, including the purpose of influencing such person to purchase Products or otherwise benefit the business of Seller. Buyer further represents and agrees that it will not receive, use, service, transfer or ship any Products from Seller in a manner or for a purpose that violates Export Laws or would cause Seller to be in violation of Export Laws. Buyer agrees to promptly and reliably provide Seller all requested information or documents, including end-user statements and other written assurances, concerning Buyer's ongoing compliance with Export Laws. 08/2020



Parker's Motion & Control Technologies

At Parker, we're guided by a relentless drive to help our customers become more productive and achieve higher levels of profitability by engineering the best systems for their requirements. It means looking at customer applications from many angles to find new ways to create value. Whatever the motion and control technology need, Parker has the experience, breadth of product and global reach to consistently deliver. No company knows more about motion and control technology than Parker. For further info call 1 800 C-Parker (1 800 272 7537)



Aerospace Key Markets

Aftermarket services
Commercial transports
Engines
General & business aviation
Helicopters
Launch vehicles
Military aircraft
Missiles
Power generation
Regional transports
Unmanned aerial vehicles

Key Products

Control systems & actuation products
Engine systems & components
Fluid conveyance systems & components
Fluid metering, delivery & atomization devices
Fuel systems & components
Fuel tank inerting systems
Hydraulic systems & components
Thermal management
Wheels & brakes



Climate Control Key Markets

Agriculture
Air conditioning
Construction Machinery
Food & beverage
Industrial machinery
Life sciences
Oil & gas
Precision cooling
Process
Refrigeration
Transportation

Key Products

Accumulators
Advanced actuators
CO₂ controls
Electronic controllers
Filter driers
Hand shut-off valves
Heat exchangers
Hose & fittings
Pressure regulating valves
Refrigerant distributors
Safety relief valves
Smart pumps
Solenoid valves
Thermostatic expansion valves



Electromechanical Key Markets

Aerospace
Factory automation
Life science & medical
Machine tools
Packaging machinery
Paper machinery
Plastics machinery & converting
Primary metals
Semiconductor & electronics
Textile
Wire & cable

Key Products

AC/DC drives & systems
Electric actuators, gantry robots & slides
Electrohydraulic actuation systems
Electromechanical actuation systems
Human machine interface
Linear motors
Stepper motors, servo motors, drives & controls
Structural extrusions



Filtration Key Markets

Aerospace
Food & beverage
Industrial plant & equipment
Life sciences
Marine
Mobile equipment
Oil & gas
Power generation & renewable energy
Process
Transportation
Water Purification

Key Products

Analytical gas generators
Compressed air filters & dryers
Engine air, coolant, fuel & oil filtration systems
Fluid condition monitoring systems
Hydraulic & lubrication filters
Hydrogen, nitrogen & zero air generators
Instrumentation filters
Membrane & fiber filters
Microfiltration
Sterile air filtration
Water desalination & purification filters & systems



Fluid & Gas Handling

Key Markets

Aerial lift
Agriculture
Bulk chemical handling
Construction machinery
Food & beverage
Fuel & gas delivery
Industrial machinery
Life sciences
Marine
Mining
Mobile
Oil & gas
Renewable energy
Transportation

Key Products

Check valves
Connectors for low pressure fluid conveyance
Deep sea umbilicals
Diagnostic equipment
Hose couplings
Industrial hose
Mooring systems & power cables
PTFE hose & tubing
Quick couplings
Rubber & thermoplastic hose
Tube fittings & adapters
Tubing & plastic fittings



Hydraulics

Key Markets

Aerial lift
Agriculture
Alternative energy
Construction machinery
Forestry
Industrial machinery
Machine tools
Marine
Material handling
Mining
Oil & gas
Power generation
Refuse vehicles
Renewable energy
Truck hydraulics
Turf equipment

Key Products

Accumulators
Cartridge valves
Electrohydraulic actuators
Human machine interfaces
Hybrid drives
Hydraulic cylinders
Hydraulic motors & pumps
Hydraulic systems
Hydraulic valves & controls
Hydrostatic steering
Integrated hydraulic circuits
Power take-offs
Power units
Rotary actuators
Sensors



Pneumatics

Key Markets

Aerospace
Conveyor & material handling
Factory automation
Life science & medical
Machine tools
Packaging machinery
Transportation & automotive

Key Products

Air preparation
Brass fittings & valves
Manifolds
Pneumatic accessories
Pneumatic actuators & grippers
Pneumatic valves & controls
Quick disconnects
Rotary actuators
Rubber & thermoplastic hose & couplings
Structural extrusions
Thermoplastic tubing & fittings
Vacuum generators, cups & sensors



Process Control

Key Markets

Alternative fuels
Biopharmaceuticals
Chemical & refining
Food & beverage
Marine & shipbuilding
Medical & dental
Microelectronics
Nuclear Power
Offshore oil exploration
Oil & gas
Pharmaceuticals
Power generation
Pulp & paper
Steel
Water/wastewater

Key Products

Analytical Instruments
Analytical sample conditioning products & systems
Chemical injection fittings & valves
Fluoropolymer chemical delivery fittings, valves & pumps
High purity gas delivery fittings, valves, regulators & digital flow controllers
Industrial mass flow meters/ controllers
Permanent no-weld tube fittings
Precision industrial regulators & flow controllers
Process control double block & bleeds
Process control fittings, valves, regulators & manifold valves



Sealing & Shielding

Key Markets

Aerospace
Chemical processing
Consumer
Fluid power
General industrial
Information technology
Life sciences
Microelectronics
Military
Oil & gas
Power generation
Renewable energy
Telecommunications
Transportation

Key Products

Dynamic seals
Elastomeric o-rings
Electro-medical instrument design & assembly
EMI shielding
Extruded & precision-cut, fabricated elastomeric seals
High temperature metal seals
Homogeneous & inserted elastomeric shapes
Medical device fabrication & assembly
Metal & plastic retained composite seals
Shielded optical windows
Silicone tubing & extrusions
Thermal management
Vibration dampening

ENGINEERING YOUR SUCCESS.

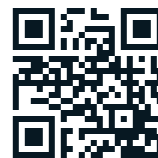

*Visit us on the web
parker.com/cylinder*

11/20 / Catalog HY08-0910-1/NA



Parker Hannifin Corporation
Cylinder Division
500 South Wolf Road
Des Plaines, IL 60016
phone (847) 298-2400
fax (800) 892-1008
www.parker.com/cylinder